



	Operating Weight	Bucket Capacity Heaped, ISO / SAE	Rated Power Gross
<i>DX140W-5</i>	34,203 lb. (15,510 kg)	0.73 yd ³ (0.56 m ³)	137 hp (102 kW)
<i>DX190W-5</i>	43,431 lb. (19,700 kg)	1.05 yd ³ (0.80 m ³)	174 hp (129 kW)
<i>DX210W-5</i>	47,179 lb. (21,400 kg)	1.12 yd ³ (0.86 m ³)	189 hp (141 kW)

WHEN YOU CHOOSE DOOSAN

as your heavy equipment brand, you'll have the backing of a strong, global organization – with benefits that extend far beyond the capabilities of a new machine.

DOOSAN

STRONG BRAND

Doosan began in 1896. Its heritage in excavators goes back to 1978. Wheel loader production began in 1992, while the company's first articulated dump truck was designed in 1972. Throughout its years in the heavy equipment industry, Doosan has listened to its North American customers, making many improvements – and developing new machines – as a result of feedback from owners and operators. From 2005 to 2015, Doosan grew from its position as the seventh-largest construction equipment manufacturer in the world to the fifth-largest.

STRONG DEALERS

Doosan serves you in partnership with its dealers – and similarly, your Doosan dealer is intended to be a trusted partner for you. Whether it's Doosan® parts, authorized service and maintenance, or even advice on how to get more value from your machine, Doosan dealers are behind you on every job.

STRONG EQUIPMENT

Doosan products are known for reliably exceeding customers' most demanding expectations. It's why we're one of the fastest-growing heavy equipment brands in North America. Doosan offers crawler excavators, wheel excavators, compact excavators, wheel loaders, articulated dump trucks, log loaders, material handlers and a variety of job-matched attachments – all designed to perform in the most difficult working conditions.

STRONG NORTH AMERICAN OPERATIONS

Doosan has built a solid infrastructure to support your equipment. It includes parts distribution in Illinois and Ontario, service training and product management in Georgia, sales training and The Real Operation Center (ROC) customer experience facility in Arizona, attachment design and development in Minnesota, plus sales and marketing support in North Dakota. We can fully support your equipment from coast to coast.

STRONG WARRANTY

Customers choose the months and hours of coverage in their transferable warranty. Options include a standard warranty of 12 months or up to 1,500 hours (depending on the machine), or up to the five-year, 7,500-hour Elite Assurance™ coverage for the powertrain only, the powertrain plus hydraulics or the full machine.

PERFORMANCE

Performance is what it's all about; Doosan delivers what you need and then some. For decades, Doosan machines have proven themselves on thousands of jobsites around the world. The undercarriage design provides superior stability and optimizes working width for superior performance in heavy digging and lifting operations. Powerful hydraulic arm and bucket forces – with horsepower to spare – help you get the job done quickly and efficiently.



Work Group Options

Customize your excavator for your job requirements with two different work group options.

Standard Boom and Arm

The standard boom and arm provides a formidable combination of reach, depth, visibility and durability that maximizes machine productivity in a wide range of applications.

Optional Articulated Two-Piece Boom

Set the variable-angle boom position for the right combination of visibility, reach and power. When you want your work closer to the machine, or if you require a more compact package for improved visibility during travel, simply retract the boom. A foot pedal in the cab provides easy boom extension and retraction.

Dozer and Outrigger Options

Two different outrigger packages ensure you can get the right combination of stability, versatility and performance for your specific applications. Outriggers can be individually positioned to level the machine on slopes.

Front Dozer with Rear Outriggers

This combination stabilizes your excavator while providing the added benefit of the front dozer blade, which can be used for backfilling.

Four Outriggers

For dedicated digging, the four-outrigger configuration provides the best stability with your wheel excavator.



WHY CHOOSE A WHEEL EXCAVATOR?

When excellent mobility is a must, a wheel excavator provides a key productivity advantage over crawler excavators. Plus, when outriggers are down, digging performance is comparable to a machine with tracks. For municipalities where road travel is necessary, or for general contracting and site development that requires frequent travel from point to point, Doosan wheel excavators are strong performers, designed from top to bottom for your most challenging tasks.

Arm and Bucket Force

Save time digging, loading trucks and more with best-in-class hydraulics. You can rely on consistent, reliable power delivery to the arm and bucket – and when you need it, a one-touch power boost momentarily amplifies your hydraulic power. With Doosan, you can confidently take on tough digging conditions that slow other machines down.

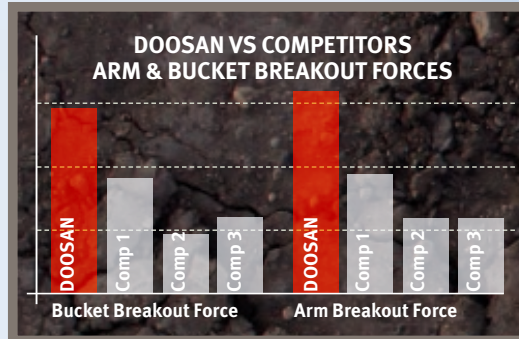

Swing Torque

Ensure that every foot of trench takes less time. Doosan wheel excavators provide plenty of swing torque, allowing you to easily swing uphill and quickly backfill with better results.



One-Touch Power Boost

The convenient button on the right-hand joystick provides momentary increased hydraulic power to break through hard ground and other tough digging conditions.



Four Power Modes

With four selectable power modes, you have more control over your excavator's performance. Balance fuel consumption and machine power to match your working conditions without even leaving the cab.

P+ **Power+ mode** delivers the fastest work group speeds to save more time loading trucks. Top digging performance delivers extra power for penetrating hard ground and other tough conditions.

P **Power mode** provides excellent power and superior performance for tough digging and heavy lifting. It also provides quick truck loading and fast travel speed to save time.

S **Standard power mode** optimizes your fuel consumption and delivers high performance in everyday digging, grading and lifting.

E **Economy mode** reduces fuel consumption for low-demand applications and slows down machine movement, which is handy for fine digging, light grading conditions and jobsite conditions that require extra precision.



Lifting Capacity

Complete the job faster and lift more with every cycle. Doosan wheel excavators are designed and tested to maximize lifting capability. An optimal swing radius, lift height and lift position enable you to confidently lift and place objects or dig loads of material in less time.

With quick cycle times, efficient designs and plenty of power, you will fit more work into fewer hours with Doosan excavators.

Precise Maneuverability

Travel controls include an economy mode and switch-activated speed control. The dynamic braking, made possible by the hydrostatic transmission, offers a smooth, steady reduction in travel speed, which is useful when maneuvering in tight areas. Just release your foot from the travel pedal to slow and gradually stop the machine.

Smart Power Control (SPC)

SPC consists of two systems that work together to improve efficiency while maintaining productivity and is controlled by the engine control unit (ECU). Each of the four power modes will function with SPC engaged or disengaged; however, SPC can only be active in the digging work mode.

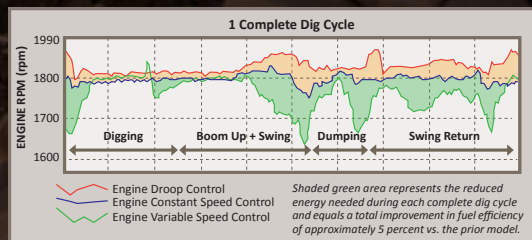

Variable Speed Control

reduces engine rpm during low workload requirements, like during the swing portion of a dig cycle. This reduces the energy used to perform a task and improves fuel efficiency by up to 5 percent.

Pump Torque Control

efficiently matches hydraulic pump torque and engine response to the task, preventing engine overload.

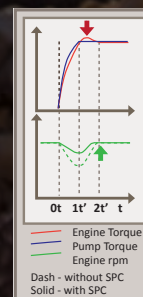

Hydrostatic Drive

The powerful hydrostatic drive on Doosan wheel excavators enables quick acceleration and precise maneuvering to enhance your productivity. Its ample power is easy to notice during tasks that require multifunctioning, when simultaneous travel and boom motion are required.





Fast Cycle Times

Two variable displacement axial piston pumps deliver fast cycle times. Hydraulic flow regeneration delivers the power you need while maximizing efficiency.

Electronic Power Optimizing System (EPOS)

The EPOS works in conjunction with the engine's ECU to monitor and optimize machine performance for increasing productivity while reducing fuel consumption.

Selectable Speed Modes

Select your range for the right balance of travel speed and torque; includes high, low or creep mode.

Auto Idle

To reduce noise, improve jobsite communications and save fuel, the standard auto idle feature idles your engine automatically when machine functions are not used for four seconds. When you move the controls, the excavator automatically returns to your previous throttle setting.

Fuel Efficiency

The engine's efficient horsepower curve delivers increased torque with less fuel. The high pressure common rail (HPCR) fuel injection system helps reduce emissions and allows the Tier 4-compliant engine to save fuel and improve performance.

Tier 4 (T4) Compliant

Optimized to provide more power output with reduced fuel consumption, Doosan excavators are designed with T4-compliant engines to reduce air pollution.



Cooled Exhaust Gas Recirculation (CEGR)

CEGR recycles a portion of the engine exhausts to reduce oxygen (O) and lower the temperature in the combustion chamber. This reduces nitrogen oxide (NO_x) emissions.

Diesel Oxidation Catalyst (DOC)

In the DOC, carbon monoxide (CO) and particulate matter (PM) emissions are transformed into harmless water (H₂O) and carbon dioxide (CO₂).

Evaporative Module

In the evaporative module, or mixing pipe, diesel exhaust fluid (DEF) solution is injected in small doses and mixed with hot exhaust gases, decomposing it into urea (CO(NH₂)₂) and water vapor, which then catalyzes into carbon dioxide and ammonia (NH₃).

Selective Catalytic Reduction (SCR)

In the SCR canister, nitrogen oxide mixes with ammonia, and a chemical reaction takes place, resulting in nitrogen (N) and water vapor emitting from the system. The SCR canister also acts as the silencer or muffler.

Diesel Exhaust Fluid (DEF)

DEF is a solution of pure urea and deionized water. A minimum level of DEF is required for proper machine operation, and the DEF supply tank is heated for proper operation in cold weather. DEF is available from your Doosan dealer in various container sizes.

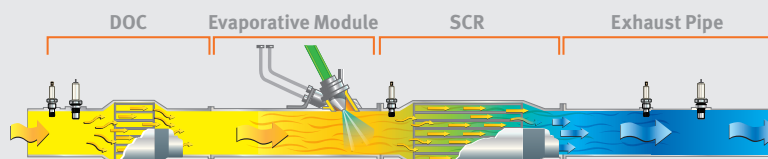

DURABILITY / RELIABILITY

Your reputation depends on a reliable, durable machine, and Doosan excavators are designed to be ready when you are. They're protected with solid construction and smart designs you can see. Their heavy-duty features keep you running longer in the field – so you spend less time in the shop and more time making money.

Air-to-Air Fuel Cooler

The air-to-air fuel cooler reduces fuel temperature to increase your machine's overall efficiency and protect engine components.

Automatic Belt Tensioner

A spring-applied automatic belt compensates for regular wear and maintains a constant tension on the engine accessory belt.

Rear-Mounted Transmission

The transmission is located directly on the fixed rear axle for protection and optimum ground clearance.

Wheel Excavator Undercarriage

A rigid, welded frame provides excellent durability throughout the undercarriage while hydraulic lines, transmission and rear differential are protected within the structure of the machine. The heavy-duty axles give you superior performance, ground clearance and component protection. A heavily reinforced chassis frame and outrigger frames stand up to the stress of severe work conditions.





D-Channel Frame Design

The Doosan frame can withstand more shock from the side thanks to an innovative upper structure frame design that adds strength and protects vital machine components.

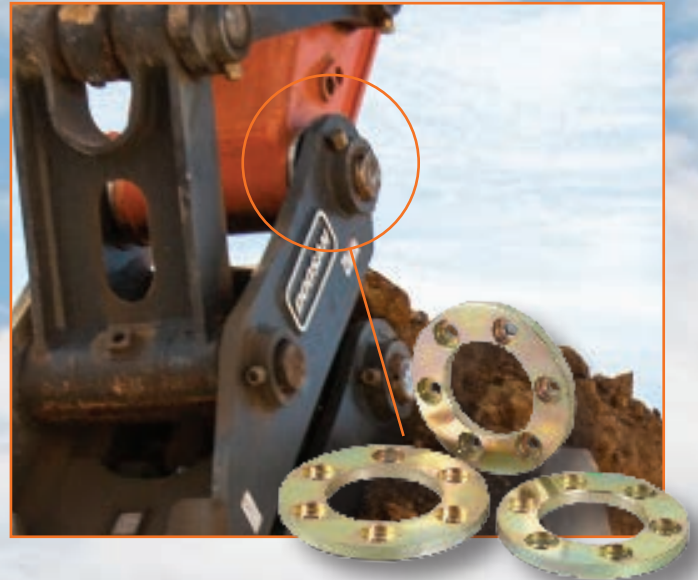

Heavy-Duty Wear Plates

Ultra-hard and wear-resistant, these plates at the end of your arm and H-link extend the service intervals for your bucket pin-up point. By minimizing the tolerance between the bucket and arm, they maintain high breakout forces and ensure greater productivity.



Cast Ends and Pin Bosses

If you want a work group that lasts in the toughest applications, take a look at Doosan.

All major pin points on the boom and arm are cast for extra strength in tough working conditions. Plus, there is additional reinforcement around the bosses and internal gussets to ensure a long life for your work group.

COMFORT

You can't do as much work if you're not comfortable. Operator comfort is essential. Great visibility, a deluxe adjustable seat, and numerous perks and comfort features help operators to push performance to the limit. Easy to enter, exit and work in, Doosan cabins give you remarkable standard features that bring superior comfort to the job.

Visibility

The Doosan cabin allows you to focus on your work – instead of struggling to see it. The large Doosan cabin provides an excellent viewing area on the front and side windows. When loading trucks or working overhead, the overhead window gives you great visibility above the machine. Narrow corner pillars, small window joints and a wiper mounted on the pillar – instead of on the glass surface – give an unobstructed view. Sun shades on the front and top windows shield operators from the sun and reduce eye strain.

Forward-Neutral-Reverse (FNR) Joystick Control

Select forward, neutral or reverse by simply pressing the appropriate joystick button. This can be done without removing your hand from the joystick, enabling greater comfort and simple control.



Other Cabin Features

- Improved floor space for your feet, increased cab space for your legs, arms and head
- 180-degree swinging door
- Wide entry/exit area
- Grab handles
- Standard AM/FM radio with MP3 player input
- 12V power port
- Adjustable side window openings

Quiet Operation

A complete, sound-isolating cabin seal reduces the noise inside the pressurized cab to an extremely low level. Compartmentalized components reduce noise output outside the cab. Even the cabin frame and seat are designed to absorb vibration and significantly increase operator comfort.

Steering Wheel

The steering wheel in your Doosan wheeled excavator is ergonomic, comfortable and easy to use. The steering wheel column can be adjusted for comfortable operation and includes a switch to select either travel or work functionality.

Work/Travel Selector Switch

Choose travel or work mode, depending on the task at hand. Travel mode locks the work group for easier movement between or across jobsites, while work mode enables full control of the machine.

Adjustable Comfort

The standard air suspension seat has multiple adjustment points, allowing you to select the most comfortable position.

- A Control Stand/Seat Base Fore/Aft
- B Control Stand/Seat Move with Suspension
- C Control Stand/Seat Height
- D Seat Fore/Aft
- E Seat Cushion Fore/Aft
- F Seat Cushion Angle
- G Back Recline
- H Lumbar Support
- I Headrest Fore/Aft and Up/Down
- J Control Stands Up/Down
- K Seat Heater
- L Adjustable Steering Wheel

Automotive-Style Heat and Air Conditioning

High capacity heating and cooling vents and an easy-to-control temperature keep you comfortable all year long. Automatic temperature control senses and adjusts to the temperature setting automatically. A memory function returns it to your preferred temperature if you shut the machine off and restart later.

Easy-to-Read LCD Display Panel

An easy-to-read LCD display panel is placed within easy view for monitoring critical machine data, fuel consumption, errors or warnings, and the rearview camera display. A big, seven-inch display also switches to a night view.



EASY MAINTENANCE



Easy Component Access

Access panels are easy to find and open from the top, bottom and sides of the excavator. A large engine cover provides plenty of room to reach the top of the engine, while a hinged belly pan allows access from the bottom. Solid steel side panels provide access to regular daily maintenance items which makes for quick, easy service and a lower cost of operation.



Even the best equipment needs regular maintenance. Doosan makes it easy to care for your excavator with onboard diagnostic systems and easy component access, plus a fleet management system that comes standard. If you want a machine that lasts, with minimal effort, Doosan delivers everything you need.

Easy access to regular inspection points

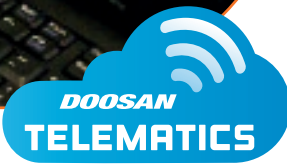

Doosan Telematics (GPS)

Doosan Telematics provides machine intelligence through a device that comes standard on all Doosan machines. The device communicates wirelessly through either cellular or satellite communication. Machine information can be viewed via the Core TMS website, which then allows you to assess various aspects of your Doosan machine.

Key benefits include:

- Review maintenance schedules
- Maximize machine utilization and uptime
- Improve operator efficiency and training
- Monitor fuel use and efficiency
- Receive theft prevention alerts



Oil and Filter Life

Easily review the hours since the last maintenance for filters and oils. Your machine will remind you when each oil and filter needs replacing 10 working hours before service is due, assisting you in regular maintenance scheduling.



Centralized Boom Grease Points

Daily maintenance is critical – and it's simple with the centralized grease banks on the base of the boom.



Doosan Monitoring System with Laptop Access

During operation, the Doosan Monitoring System monitors all critical data and provides a complete history of operation and a real-time log of machine failures to your dealer's technician. Armed with information like this, dealer service personnel can fix issues faster – and you can get back to work.

Auxiliary Mode Switch

If needed, an auxiliary mode switch allows you to finish a job or move your excavator to a convenient location for service.

Self-Diagnostics

An LCD monitor helps you track critical systems in real time and access historical machine alerts from within the cabin.

VERSATILITY

Doosan excavators are made to do more because they are optimized for attachment versatility. You'll find a variety of Doosan attachments matched to your excavator's operating weight – so you can easily increase productivity and utilization.

Selectable Work Modes

Tailor your excavator's performance to the job at hand with four unique work modes. Two modes recalibrate machine power for digging or lifting. Two change the auxiliary hydraulic flow for specific types of attachments. Just change a few settings with the LCD display panel to quickly optimize performance and protect your hydraulic components.

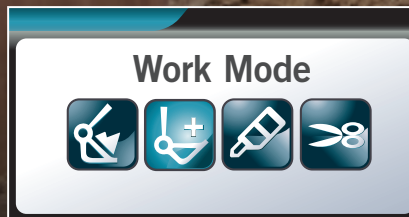

Digging

Your default setting delivers the performance you need for general excavation, loading and lifting. The four power modes give it a huge range of versatility for many different digging applications.



Lifting

The increased pump torque, low engine rpm and automatic power boost provide extra muscle when lifting materials – like pipe or concrete barriers.

Doosan Attachments

Gear up for your job with the hard-working line of Doosan attachments for excavators and loaders. Doosan builds its own tough quick couplers, breakers, clamps, plate compactors and a wide array of bucket types and sizes. All of them are built and matched to Doosan machine specifications for superior reliability and performance.



Clamp



Plate compactor



Quick coupler, hydraulic & power tilting & wedgelock



Bucket, angle tilt



Breaker



Bucket, heavy-duty & severe-duty



Bucket, heavy-duty ditching



Hydraulic Attachment Management

Using the LCD screen, the operator can configure 10 different attachment presets: five each for one-way and two-way flow. Each preset selection can be matched to specific operational requirements of an attachment by limiting the maximum pressure and the minimum/maximum flow rate that is delivered to the attachment.

When changing hydraulic attachments, the operator can easily select the appropriate preset to optimize machine and attachment functionality. Password protection functionality within the system discourages improper attachment preset selection for operators or rental users with limited understanding of hydraulic systems.

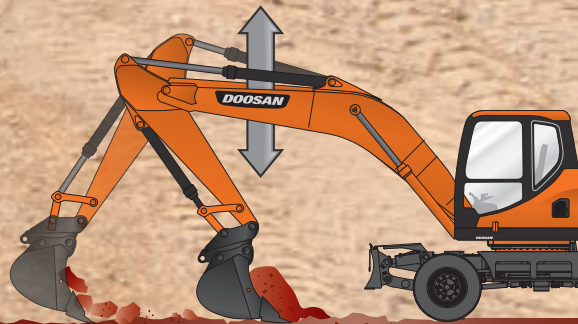

Intelligent Floating Boom (Optional)

Ideal for finishing work, operators can focus on the arm and bucket with the intelligent floating boom. This setting allows the boom to move freely with the contours of the ground. When engaged, the boom does not utilize hydraulic flow, increasing efficiency and productivity by saving fuel and improving cycle times.



Breaker, or one-way auxiliary hydraulic flow, works great for attachments that only require hydraulic power from one direction, such as breakers or plate compactors. This mode also maintains consistent downward pressure for maximum attachment performance and component protection.



Shear, or two-way auxiliary hydraulic flow, is ideal for attachments that need bi-directional hydraulic flow, such as a hydraulic clamp or tilting bucket.

Roller Switch

Easily control and vary the speed at which a two-way hydraulic attachment functions, such as opening and closing a hydraulic clamp, with the roller switch on the right joystick. Hydraulic flow can now be controlled by the joystick or the new foot pedal for operator convenience.



General

	UNIT	DX140W-5 Standard Arm (US20)	DX190W-5 Standard Arm (US20)	DX210W-5 Standard Arm (US20)
ENGINE				
MAKE		Doosan	Doosan	Doosan
MODEL		DL06P	DL06P	DL06P
NUMBER OF CYLINDERS		6	6	6
RATED POWER GROSS (HP PER SAE J1995)	hp (kW) @ rpm	137 (102) @ 2000	174 (129) @ 1900	189 (141) @ 1900
RATED POWER NET (HP PER SAE J1349)	hp (kW) @ rpm	124 (93) @ 2000	168 (125) @ 1900	187 (139) @ 1900
MAXIMUM TORQUE (GROSS) (SAE J1995)	ft.-lb. (Nm) @ rpm	443 (601) @ 1400	557 (755) @ 1400	583 (790) @ 1400
PISTON DISPLACEMENT	in ³ (L)	359 (5.9)	359 (5.9)	359 (5.9)
BORE AND STROKE	in. x in. (mm x mm)	3.9" x 4.9" (100 x 125)	3.9" x 4.9" (100 x 125)	3.9" x 4.9" (100 x 125)
STARTER	V, hp (kW)	24V, 8 (6)	24V, 8 (6)	24V, 8 (6)
BATTERY (QTY 2)	V, AH	24V, 150AH	24V, 150AH	24V, 150AH
ALTERNATOR	V, amp	24V, 80 A	24V, 80 A	24V, 80 A
AIR CLEANER		Double Elements	Double Elements	Double Elements
HYDRAULICS				
MAIN PUMPS	gpm (L/min)	2 x 44.9 (2 x 170)	2 x 52.8 (2 x 200)	2 x 62.3 (2 x 236)
PILOT PUMP (GEAR DESIGN)	gpm (L/min)	6.4 (24.1)	6.9 (26.1)	7.2 (27.4)
RELIEF PRESSURE (NORMAL)	psi (kg/cm ²)	4975 (349.8)	5076 (356.9)	5076 (356.9)
RELIEF PRESSURE (BOOST)	psi (kg/cm ²)	5265 (370.2)	5076 (356.9)	5076 (356.9)
MAXIMUM SYSTEM PRESSURE				
BOOM/ARM/BUCKET (NORMAL MODE)	psi (kg/cm ²)	4975 (349.8)	5076 (356.9)	5076 (356.9)
BOOM/ARM/BUCKET (POWER MODE)	psi (kg/cm ²)	5265 (370.2)	5076 (356.9)	5076 (356.9)
TRAVEL (NORMAL MODE)	psi (kg/cm ²)	4975 (349.8)	5076 (356.9)	5076 (356.9)
TRAVEL (POWER MODE)	psi (kg/cm ²)	5265 (370.2)	5076 (356.9)	5076 (356.9)
SWING (NORMAL MODE)	psi (kg/cm ²)	4975 (349.8)	5076 (356.9)	5076 (356.9)
SWING (POWER MODE)	psi (kg/cm ²)	5265 (370.2)	5076 (356.9)	5076 (356.9)
SWING MECHANISM				
SWING SPEED	rpm	0 - 11.4	0 - 10.9	0 - 9.8
SWING TORQUE	lbf.-ft. (kgf-m)	34,718 (4800)	46,638 (6448)	59,224 (8188)
DRIVE SYSTEM				
TRAVEL SPEED [CREEP - LOW - HIGH]	mph (km/h)	2.2 - 6.2 - 23 (3.5 - 10 - 37)	1.9 - 5.3 - 22 (3.0 - 8.5 - 35)	2.5 - 5.6 - 22 (4.0 - 9.0 - 35)
TRACTION FORCE (DRAWBAR PULL)	lbf. (kgf)	16,965 (7695)	24,295 (11,020)	27,172 (12,325)
MAXIMUM GRADE	% (°)	62 (32)	68 (34)	65 (33)
ENVIRONMENT				
SOUND LEVEL (2000/14/EC)	dB(A)	101	100	101
CABIN SOUND LEVEL (ISO 6396)	dB(A)	70	70	70
REFILL CAPACITIES				
FUEL TANK	gal. (L)	74.0 (280.0)	81.9 (310.0)	79.3 (300.0)
DEF TANK	gal. (L)	8.3 (31.5)	8.3 (31.5)	8.3 (31.5)
COOLING SYSTEM (RADIATOR CAPACITY)	gal. (L)	5.3 (20.0)	6.3 (24.0)	6.3 (24.0)
ENGINE OIL	gal. (L)	5.8 (22.0)	6.6 (25.0)	7.1 (27.0)
SWING DRIVE	gal. (L)	0.79 (3.00)	1.32 (5.00)	1.32 (5.00)
FRONT AXLE	gal. (L)	2.38 (9.00)	2.77 (10.50)	2.91 (11.00)
FRONT HUB (2x)	gal. (L)	0.66 (2.5)	0.66 (2.5)	0.66 (2.5)
REAR AXLE	gal. (L)	2.96 (11.20)	3.70 (14.00)	3.83 (14.50)
REAR HUB (2x)	gal. (L)	0.63 (2.4)	0.66 (2.5)	0.66 (2.5)
TRANSMISSION	gal. (L)	0.66 (2.5)	0.66 (2.5)	0.66 (2.5)
HYDRAULIC SYSTEM	gal. (L)	62.9 (238)	76.6 (290)	76.6 (290)
HYDRAULIC TANK	gal. (L)	39.1 (148)	50.7 (192)	54.7 (207)

NOTE — Where applicable, dimensions are in accordance with Society of Automotive Engineers (SAE) and ISO standards. Specifications and design are subject to change without notice. Pictures of Doosan excavators may show other than standard equipment. All dimensions are shown in inches. Respective metric dimensions are enclosed by parentheses. Doosan Construction Equipment is manufactured with a Quality Management System that is in compliance with ISO 9001:2008.

All dimensions are given for Doosan excavators equipped with standard tracks and the standard front as listed.

Hydraulic Cylinders

	UNIT	DX140W-5 Mono Boom (US20/30)	DX140W-5 Art. Boom (US40/50)	DX190W-5 Mono Boom (US20/30)	DX190W-5 Art. Boom (US40/50)	DX210W-5 Mono Boom (US20/30)	DX210W-5 Art. Boom (US40/50)
BOOM, MAIN (2)							
BORE x ROD DIAMETER x STROKE	in. x in. x in. (mm x mm x mm)	4.3" x 3" x 40.7" (110 x 75 x 1035)	4.3" x 3" x 38.4" (110 x 75 x 975)	4.7" x 3.3" x 46.5" (120 x 85 x 1180)	4.7" x 3.3" x 40" (120 x 85 x 1015)	4.7" x 3.3" x 48.8" (120 x 85 x 1240)	4.7" x 3.3" x 41.1" (120 x 85 x 1045)
BOOM, ARTICULATED (1)							
BORE x ROD DIAMETER x STROKE	in. x in. x in. (mm x mm x mm)	-	5.5" x 3.3" x 28.3" (140 x 85 x 720)	-	4.9" x 3.5" x 57.9" (125 x 90 x 1470)	-	6.7" x 4.1" x 29.4" (170 x 105 x 748)
ARM* (1)							
BORE x ROD DIAMETER x STROKE	in. x in. x in. (mm x mm x mm)	4.3" x 3.0" x 40.7" (110 x 75 x 1035)	4.5" x 3.1" x 42.0" (115 x 80 x 1068)	4.9" x 3.5" x 57.9" (125 x 90 x 1470)		5.3" x 3.3" x 57.1" (135 x 85 x 1450)	
BUCKET (1)							
BORE x ROD DIAMETER x STROKE	in. x in. x in. (mm x mm x mm)	3.7" x 2.6" x 35.4" (95 x 65 x 900)		4.3" x 3" x 40.6" (110 x 75 x 1030)		4.7" x 3.1" x 41.7" (120 x 80 x 1060)	
STEERING (1)							
BORE x ROD DIAMETER x STROKE	in. x in. x in. (mm x mm x mm)	3.5" x 2.0" x 3.5" (90 x 50 x 90)		3.5" x 2.0" x 3.5" (90 x 50 x 90)		3.9" x 2" x 3.4" (100 x 50 x 86)	
LEVELING (1)							
BORE x ROD DIAMETER x STROKE	in. x in. x in. (mm x mm x mm)	3.9" x 3.9" x 6" (100 x 100 x 153)		3.9" x 3.9" x 6" (100 x 100 x 153)		3.9" x 3.9" x 6" (100 x 100 x 153)	
DOZER (2)							
BORE x ROD DIAMETER x STROKE	in. x in. x in. (mm x mm x mm)	3.9" x 3.5" x 8" (100 x 90 x 204)		4.3" x 2.8" x 6.7" (110 x 70 x 170)		5.1" x 3.1" x 6.3" (130 x 80 x 160)	
OUTRIGGER (2 or 4)							
BORE x ROD DIAMETER x STROKE	in. x in. x in. (mm x mm x mm)	4.3" x 2.8" x 17.2" (110 x 70 x 438)		5.1" x 3.1" x 15.6" (130 x 80 x 397)		5.1" x 3.1" x 15.4" (130 x 80 x 391)	

The piston rods and cylinder bodies are made of high-strength steel. A cushioning mechanism is fitted in all cylinders to ensure shock-free operation and extended piston life.

*does not include cushioning

Bucket

	Mono Boom Dozer / Outriggers (2 R) (US20)		Mono Boom Outriggers (2 F / 2 R) (US30)		Articulated Boom Dozer / Outriggers (2 R) (US40)		Articulated Boom Outriggers (2 F / 2 R) (US50)	
BOOM, MAIN ft.-in. (mm)	14' 5" (4400)				11' (3350)			
BOOM, ART. ft.-in. (mm)	-				7' 3" (2200)			
ARM ft.-in. (mm)	6' 11" (2100)							
MOUNT	PIN-ON	QUICK COUPLER	PIN-ON	QUICK COUPLER	PIN-ON	QUICK COUPLER	PIN-ON	QUICK COUPLER

DX140W-5

BUCKET TYPE	MODEL	CAPACITY ¹ yd ³ (m ³)	WIDTH in. (mm)	WEIGHT lb. (kg)	A	A	A	A	A	A	A	A
HEAVY DUTY ^{2,3}	HF40-018	0.30 (0.23)	20 (508)	772 (350)	A	A	A	A	A	A	A	A
	HF40-024	0.42 (0.32)	26 (660)	878 (398)	A	A	A	A	A	A	A	A
	HF40-030	0.56 (0.43)	32 (813)	1013 (459)	A	A	A	A	A	A	A	A
	HF40-036	0.71 (0.54)	38 (965)	1147 (520)	A	A	A	A	A	A	A	A
	HF40-042	0.85 (0.65)	44 (1118)	1253 (568)	A	A	A	A	A	A	A	A
SEVERE DUTY ^{2,3}	SF40-018	0.30 (0.23)	20 (508)	994 (451)	A	A	A	A	A	A	A	A
	SF40-024	0.42 (0.32)	26 (660)	1069 (485)	A	A	A	A	A	A	A	A
	SF40-030	0.56 (0.43)	32 (813)	1168 (530)	A	A	A	A	A	A	A	A
	SF40-036	0.71 (0.54)	38 (965)	1415 (642)	A	A	A	A	A	A	A	A
	SF40-042	0.85 (0.65)	44 (1118)	1488 (675)	A	A	A	A	A	A	A	A
DITCHING ⁴	DX140BS8B48	0.64 (0.49)	48 (1219)	602 (273)	A	A	A	A	A	A	A	A
	DX140BS8B60	0.80 (0.61)	60 (1524)	908 (412)	A	A	A	A	A	A	A	A
HEAVY DUTY DITCHING	DX140H14WB1500	1.39 (1.06)	60 (1524)	1548 (702)	*	*	*	*	*	*	*	*
TILTING BUCKET - 90°	AT18R-1500	0.82 (0.63)	60 (1524)	1500 (680)	A	A	A	A	A	A	A	A
	AT18R-1800	1.05 (0.80)	72 (1823)	1600 (726)	A	A	A	A	A	A	A	A

- | | |
|--------------------------------------|--|
| 1 Capacity based on ISO 7451 | Maximum Suitable Material Density |
| 2 Equipped with Side Cutters | A 3370 lb./yd ³ (2000 kg/m ³) |
| 3 Equipped with Bolt On Teeth | B 2700 lb./yd ³ (1600 kg/m ³) |
| 4 Equipped with Bolt On Cutting Edge | C 1850 lb./yd ³ (1100 kg/m ³) |
| | X Not Approved |

* Based on designed use,
not material capacity.

Specifications

Bucket

DX190W-5

	Mono Boom Dozer / Outriggers (2 R) (US20)		Mono Boom Outriggers (2 F / 2 R) (US30)		Articulated Boom Dozer / Outriggers (2 R) (US40)		Articulated Boom Outriggers (2 F / 2 R) (US50)	
BOOM, MAIN ft.-in. (mm)	17' 1" (5200)				12' 6" (3820)			
BOOM, ART. ft.-in. (mm)	-				6' 4" (1940)			
ARM ft.-in. (mm)	8' 6" (2600)				8' 6" (2600)		7' 7" (2300)	
MOUNT	PIN ON	QUICK COUPLER	PIN-ON	QUICK COUPLER	PIN-ON	QUICK COUPLER	PIN-ON	QUICK COUPLER

BUCKET TYPE	MODEL	CAPACITY ¹ yd ³ (m ³)	WIDTH in. (mm)	WEIGHT lb. (kg)								
HEAVY DUTY ^{2,3}	HF46-018	0.38 (0.29)	20 (508)	973 (441)	A	A	A	A	A	A	A	A
	HF46-024	0.55 (0.42)	26 (660)	1107 (502)	A	A	A	A	A	A	A	A
	HF46-030	0.72 (0.55)	32 (813)	1266 (574)	A	A	A	A	A	A	A	A
	HF46-036	0.90 (0.69)	38 (965)	1424 (646)	A	A	A	A	A	A	A	A
	HF46-042	1.08 (0.83)	44 (1118)	1557 (706)	A	A	A	A	A	A	A	A
	HF46-048	1.26 (0.96)	50 (1270)	1790 (812)	A	A	A	A	A	B	A	A
SEVERE DUTY ^{2,3}	SF46-018	0.38 (0.29)	20 (508)	1027 (466)	A	A	A	A	A	A	A	A
	SF46-024	0.55 (0.42)	26 (660)	1215 (551)	A	A	A	A	A	A	A	A
	SF46-030	0.72 (0.55)	32 (813)	1382 (627)	A	A	A	A	A	A	A	A
	SF46-036	0.90 (0.69)	38 (965)	1528 (693)	A	A	A	A	A	A	A	A
	SF46-042	1.08 (0.83)	44 (1118)	1687 (765)	A	A	A	A	A	A	A	A
	SF46-048	1.26 (0.96)	50 (1270)	1841 (835)	A	A	A	A	A	A	A	A
DITCHING ⁴	BS8B48	0.75 (0.57)	48 (1219)	602 (273)	A	A	A	A	A	A	A	A
	BS8B60	0.80 (0.61)	60 (1524)	908 (412)	A	A	A	A	A	A	A	A
	BS8B72	0.98 (0.75)	72 (1829)	1047 (475)	A	A	A	A	A	A	A	A
HEAVY DUTY DITCHING	H18BW1500	1.64 (1.25)	60 (1524)	1987 (901)	*	*	*	*	*	*	*	*
	H18BW1700	1.89 (1.45)	67 (1702)	2193 (995)	*	*	*	*	*	*	*	*
TILTING BUCKET - 90°	AT18R-1500	0.82 (0.63)	60 (1524)	1500 (680)	A	A	A	A	A	A	A	A
	AT18R-1800	1.05 (0.80)	72 (1823)	1600 (726)	A	A	A	A	A	A	A	A

- 1 Capacity based on ISO 7451
- 2 Equipped with Side Cutters
- 3 Equipped with Bolt On Teeth
- 4 Equipped with Bolt On Cutting Edge

Maximum Suitable Material Density
 A 3370 lb./yd³ (2000 kg/m³)
 B 2700 lb./yd³ (1600 kg/m³)
 C 1850 lb./yd³ (1100 kg/m³)
 X Not Approved

* Based on designed use,
not material capacity.

Bucket

DX210W-5

	Mono Boom Dozer / Outriggers (2 R) (US20)		Mono Boom Outriggers (2 F / 2 R) (US30)		Articulated Boom Dozer / Outriggers (2 R) (US40)		Articulated Boom Outriggers (2 F / 2 R) (US50)	
BOOM, MAIN ft.-in. (mm)	18' 4" (5600)				12' 7" (3840)			
BOOM, ART. ft.-in. (mm)	-				6' 4" (1920)			
ARM ft.-in. (mm)	9' (2750)				7' 10" (2400)			
MOUNT	PIN ON	QUICK COUPLER	PIN-ON	QUICK COUPLER	PIN-ON	QUICK COUPLER	PIN-ON	QUICK COUPLER

BUCKET TYPE	MODEL	CAPACITY ¹ yd ³ (m ³)	WIDTH in. (mm)	WEIGHT lb. (kg)									
HEAVY DUTY ^{2,3}	HF49-024	0.59 (0.45)	26 (660)	1277 (579)	A	A	A	A	A	A	A	A	A
	HF49-030	0.78 (0.60)	32 (813)	1466 (665)	A	A	A	A	A	A	A	A	A
	HF49-036	0.99 (0.76)	38 (965)	1665 (755)	A	A	A	A	A	A	A	A	A
	HF49-042	1.20 (0.92)	44 (1118)	1820 (826)	A	A	A	A	A	A	A	A	A
	HF49-048	1.41 (1.08)	50 (1270)	1976 (896)	A	A	A	A	A	A	A	A	A
SEVERE DUTY ^{2,3}	SF49-024	0.65 (0.50)	26 (660)	1643 (745)	A	A	A	A	A	A	A	A	A
	SF49-030	0.85 (0.65)	32 (813)	1795 (814)	A	A	A	A	A	A	A	A	A
	SF49-036	1.06 (0.81)	38 (965)	1916 (869)	A	A	A	A	A	A	A	A	A
	SF49-042	1.28 (0.98)	44 (1118)	2189 (993)	A	A	A	A	A	A	A	A	A
	SF49-048	1.49 (1.14)	50 (1270)	2431 (1103)	A	A	A	A	A	A	A	A	A
DITCHING ⁴	B33B48	0.93 (0.71)	48 (1219)	903 (410)	A	A	A	A	A	A	A	A	A
	B33B60	0.98 (0.75)	60 (1524)	1307 (593)	A	A	A	A	A	A	A	A	A
	B33B72	1.20 (0.92)	72 (1829)	1499 (680)	A	A	A	A	A	A	A	A	A
HEAVY DUTY DITCHING	H25BW1500	1.92 (1.47)	60 (1524)	2213 (1004)	*	*	*	*	*	*	*	*	*
	H25BW1700	2.22 (1.70)	67 (1702)	2441 (1107)	*	*	*	*	*	*	*	*	*
	LP25BW1850	1.67 (1.28)	73 (1854)	2153 (977)	*	*	*	*	*	*	*	*	*
TILTING BUCKET - 90°	AT25R-1500	1.11 (0.85)	60 (1524)	1981 (898)	A	A	A	A	A	A	A	A	A
	AT25R-1800	1.71 (1.31)	72 (1823)	2382 (1081)	B	B	A	A	B	B	B	B	B

- 1 Capacity based on ISO 7451
- 2 Equipped with Side Cutters
- 3 Equipped with Bolt On Teeth
- 4 Equipped with Bolt On Cutting Edge

- Maximum Suitable Material Density
- A 3370 lb./yd³ (2000 kg/m³)
 - B 2700 lb./yd³ (1600 kg/m³)
 - C 1850 lb./yd³ (1100 kg/m³)
 - X Not Approved

* Based on designed use, not material capacity.

Specifications

Dimensions

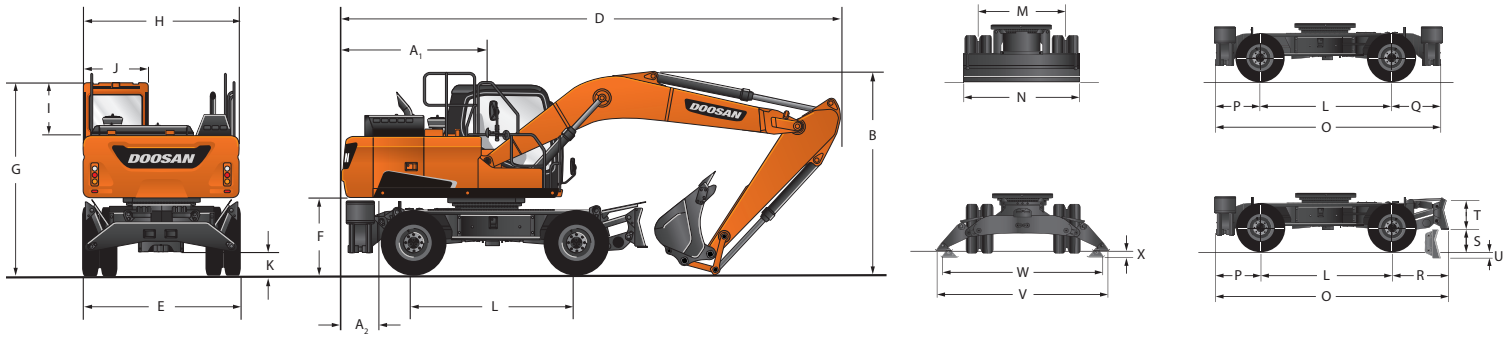

DX140W-5

			Mono Boom Dozer / Outriggers (2 R) (US20)	Mono Boom Outriggers (2 F / 2 R) (US30)	Articulated Boom Dozer / Outriggers (2 R) (US40)	Articulated Boom Outriggers (2 F / 2 R) (US50)
BOOM, MAIN		ft.-in. (mm)	14' 5" (4400)			11' (3350)
BOOM, ARTICULATED			-			7' 3" (2200)
ARM		ft.-in. (mm)	6' 11" (2100)			
BUCKET TYPE (SAE)		yd ³ (m ³)	0.73 (0.56)			
TAIL SWING RADIUS	A ₁	ft.-in. (mm)	7' 3" (2205)			
TAIL SWING OVERHANG (REAR)	A ²	ft.-in. (mm)	-0.2" (-4.00)			
TAIL SWING OVERHANG (FRONT)	A ₃ *	ft.-in. (mm)	-1' 9" (-543)	-1' 11" (-582)	-1' 9" (-543)	-1' 11" (-582)
TAIL SWING OVERHANG (SIDE)**	A ₄ *	ft.-in. (mm)	1' 8" (502)			
SHIPPING HEIGHT (HOSE)	B	ft.-in. (mm)	9' 10" (2995)			9' 8" (2940)
SHIPPING LENGTH	D	ft.-in. (mm)	24' 4" (7420)			26' 3" (8010)
SHIPPING WIDTH	E	ft.-in. (mm)	8' 2" (2500)			
COUNTERWEIGHT CLEARANCE	F	ft.-in. (mm)	4' (1215)			
CABIN HEIGHT	G	ft.-in. (mm)	10' 8" (3242)			
UPPER STRUCTURE WIDTH	H	ft.-in. (mm)	8' 2" (2490)			
CABIN HEIGHT ABOVE HOUSE	I	ft.-in. (mm)	3' 4" (1027)			
CABIN WIDTH	J	ft.-in. (mm)	3' 4" (1010)			
CAR BODY CLEARANCE	K	ft.-in. (mm)	1' 2" (347)			
WHEEL BASE	L	ft.-in. (mm)	9' 2" (2800)			
TREAD WIDTH	M	ft.-in. (mm)	6' 5" (1944)			
BLADE WIDTH	N	ft.-in. (mm)	8' 2" (2495)	-	8' 2" (2495)	-
OVERALL UNDERCARRIAGE LENGTH	O	ft.-in. (mm)	16' 3" (4957)	16' 5" (4996)	16' 3" (4957)	16' 5" (4996)
OUTRIGGER LENGTH (REAR)	P	ft.-in. (mm)	3' 8" (1109)			
OUTRIGGER LENGTH (FRONT)	Q	ft.-in. (mm)	-	3' 7" (1087)	-	3' 7" (1087)
BLADE LENGTH (FRONT)	R	ft.-in. (mm)	3' 5" (1048)	-	3' 5" (1048)	-
BLADE CLEARANCE (RAISED)	S	ft.-in. (mm)	1' 7" (472)			
BLADE HEIGHT	T	ft.-in. (mm)	2' 2" (652)			
MAX. BLADE DEPTH	U	ft.-in. (mm)	5.0" (128)			
OUTRIGGER WIDTH (GROUND)	V	ft.-in. (mm)	11' 11" (3631)			
OUTRIGGER WIDTH (MAX DEPTH)	W	ft.-in. (mm)	11' 2" (3406)			
MAX. OUTRIGGER DEPTH	X	ft.-in. (mm)	-6.0" (-152)			
TIRE SIZE	-		8 x 10.00R20			

* Not Shown

** Outrigger Width (Ground Level)

*** Dozer Lowered to Ground

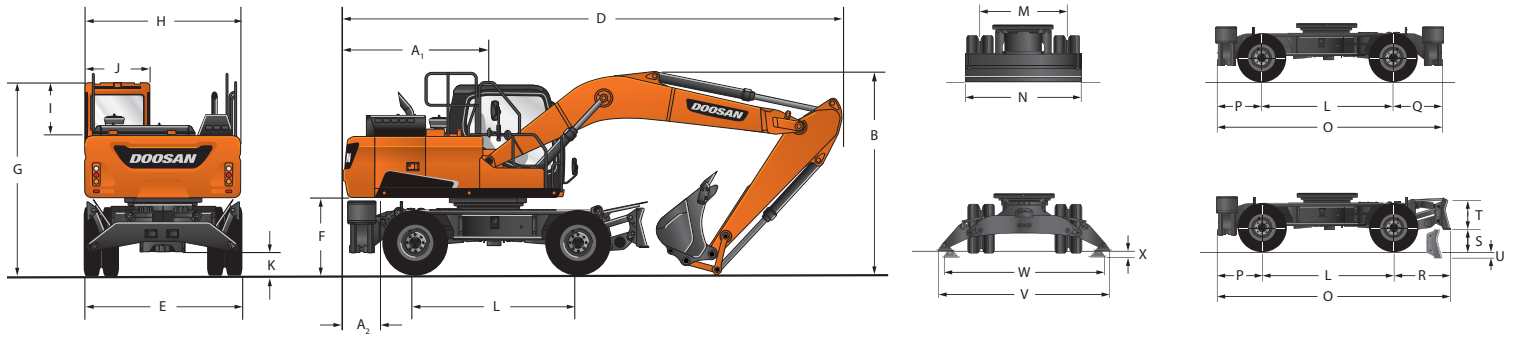

DX190W-5

			Mono Boom Dozer / Outriggers (2 R) (US20)	Mono Boom Outriggers (2 F / 2 R) (US30)	Articulated Boom Dozer / Outriggers (2 R) (US40)	Articulated Boom Outriggers (2 F / 2 R) (US50)
BOOM, MAIN		ft.-in. (mm)	17' 1" (5200)		12' 6" (3820)	
BOOM, ARTICULATED			-		6' 4" (1940)	
ARM		ft.-in. (mm)	8' 6" (2600)		8' 6" (2600)	7' 7" (2300)
BUCKET TYPE (SAE)		yd ³ (m ³)	1.05 (0.80)			
TAIL SWING RADIUS	A ₁	ft.-in. (mm)	8' 5" (2555)			
TAIL SWING OVERHANG (REAR)	A ²	ft.-in. (mm)	1' 1" (322)			
TAIL SWING OVERHANG (FRONT)	A ₃ *	ft.-in. (mm)	-4.0" (-101)	0.6" (14)	-4.0" (-101)	0.6" (14)
TAIL SWING OVERHANG (SIDE)**	A ₄ *	ft.-in. (mm)	2' 4" (707)			
SHIPPING HEIGHT (HOSE)	B	ft.-in. (mm)	9' 4" (2840)		10' 5" (3170)	
SHIPPING LENGTH	D	ft.-in. (mm)	28' 8" (8750)		29' 9" (9070)	
SHIPPING WIDTH	E	ft.-in. (mm)	8' 4" (2530)			
COUNTERWEIGHT CLEARANCE	F	ft.-in. (mm)	4' 1" (1249)			
CABIN HEIGHT	G	ft.-in. (mm)	10' 3" (3134)			
UPPER STRUCTURE WIDTH	H	ft.-in. (mm)	8' 4" (2530)			
CABIN HEIGHT ABOVE HOUSE	I	ft.-in. (mm)	2' 9" (838)			
CABIN WIDTH	J	ft.-in. (mm)	3' 4" (1010)			
CAR BODY CLEARANCE	K	ft.-in. (mm)	1' 2" (347)			
WHEEL BASE	L	ft.-in. (mm)	8' 8" (2650)			
TREAD WIDTH	M	ft.-in. (mm)	6' 3" (1914)			
BLADE WIDTH	N	ft.-in. (mm)	8' 4" (2530)	-	8' 4" (2530)	-
OVERALL UNDERCARRIAGE LENGTH	O	ft.-in. (mm)	15' 10" (4826)	15' 8" (4769)	15' 10" (4826)	15' 8" (4769)
OUTRIGGER LENGTH (REAR)	P	ft.-in. (mm)	3' 5" (1033)			
OUTRIGGER LENGTH (FRONT)	Q	ft.-in. (mm)	-	3' 7" (1086)	-	3' 7" (1086)
BLADE LENGTH (FRONT)	R	ft.-in. (mm)	3' 9" (1143)	-	3' 9" (1143)	-
BLADE CLEARANCE (RAISED)	S	ft.-in. (mm)	1' 6" (448)			
BLADE HEIGHT	T	ft.-in. (mm)	2' 1" (628)			
MAX. BLADE DEPTH	U	ft.-in. (mm)	5.3" (135)			
OUTRIGGER WIDTH (GROUND)	V	ft.-in. (mm)	12' 1" (3,696)			
OUTRIGGER WIDTH (MAX DEPTH)	W	ft.-in. (mm)	11' 9" (3569)			
MAX. OUTRIGGER DEPTH	X	ft.-in. (mm)	3.5" (90)			
TIRE SIZE	-		8 x 10.00R20			

- * Not Shown
- ** Outrigger Width (Ground Level)
- *** Dozer Lowered to Ground

Specifications

Dimensions

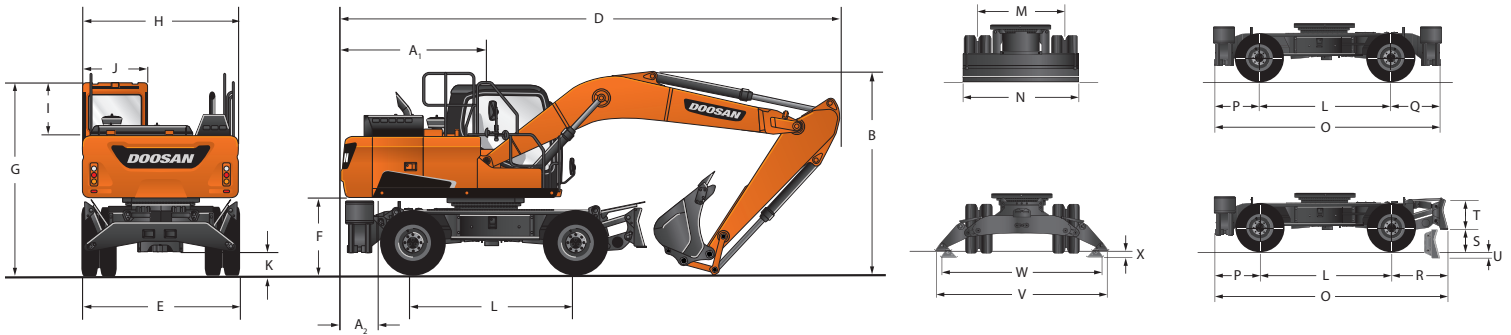

DX210W-5

			Mono Boom Dozer / Outriggers (2 R) (US20)	Mono Boom Outriggers (2 F / 2 R) (US30)	Articulated Boom Dozer / Outriggers (2 R) (US40)	Articulated Boom Outriggers (2 F / 2 R) (US50)
BOOM, MAIN		ft.-in. (mm)	18' 4" (5600)		12' 7" (3840)	
BOOM, ARTICULATED			-		6' 4" (1920)	
ARM		ft.-in. (mm)	9' (2750)		7' 10" (2400)	
BUCKET TYPE (SAE)		yd ³ (m ³)	1.12 (0.86)			
TAIL SWING RADIUS	A ₁	ft.-in. (mm)	9' (2755)			
TAIL SWING OVERHANG (REAR)	A ²	ft.-in. (mm)	1' 9" (522)			
TAIL SWING OVERHANG (FRONT)	A ₃ *	ft.-in. (mm)	6.4" (162)	8.6" (219)	6.4" (162)	8.6" (219)
TAIL SWING OVERHANG (SIDE)**	A ₄ *	ft.-in. (mm)	3' 1" (935)			
SHIPPING HEIGHT (HOSE)	B	ft.-in. (mm)	10' 1" (3080)		10' 4" (3140)	
SHIPPING LENGTH	D	ft.-in. (mm)	30' 11" (9420)		30' 3" (9225)	
SHIPPING WIDTH	E	ft.-in. (mm)	8' 4" (2530)			
COUNTERWEIGHT CLEARANCE	F	ft.-in. (mm)	4' 1" (1255)			
CABIN HEIGHT	G	ft.-in. (mm)	10' 4" (3140)			
UPPER STRUCTURE WIDTH	H	ft.-in. (mm)	8' 4" (2530)			
CABIN HEIGHT ABOVE HOUSE	I	ft.-in. (mm)	2' 9" (838)			
CABIN WIDTH	J	ft.-in. (mm)	3' 4" (1010)			
CAR BODY CLEARANCE	K	ft.-in. (mm)	1' 1" (336)			
WHEEL BASE	L	ft.-in. (mm)	9' 4" (2850)			
TREAD WIDTH	M	ft.-in. (mm)	6' 3" (1914)			
BLADE WIDTH	N	ft.-in. (mm)	8' 4" (2530)	-	8' 4" (2530)	-
OVERALL UNDERCARRIAGE LENGTH	O	ft.-in. (mm)	16' 8" (5080)	16' 3" (4965)	16' 8" (5080)	16' 3" (4965)
OUTRIGGER LENGTH (REAR)	P	ft.-in. (mm)	3' 3" (999)			
OUTRIGGER LENGTH (FRONT)	Q	ft.-in. (mm)	-	3' 8" (1116)	-	3' 8" (1116)
BLADE LENGTH (FRONT)	R	ft.-in. (mm)	4' (1231)	-	4' (1231)	-
BLADE CLEARANCE (RAISED)	S	ft.-in. (mm)	1' 6" (445)			
BLADE HEIGHT	T	ft.-in. (mm)	2' 1" (630)			
MAX. BLADE DEPTH	U	ft.-in. (mm)	4.9" (125)			
OUTRIGGER WIDTH (GROUND)	V	ft.-in. (mm)	11' 4" (3465)			
OUTRIGGER WIDTH (MAX DEPTH)	W	ft.-in. (mm)	11' 11" (3640)			
MAX. OUTRIGGER DEPTH	X	ft.-in. (mm)	3.5" (90)			
TIRE SIZE	-		8 x 10.00R20			

* Not Shown

** Outrigger Width (Ground Level)

*** Dozer Lowered to Ground

Working Range

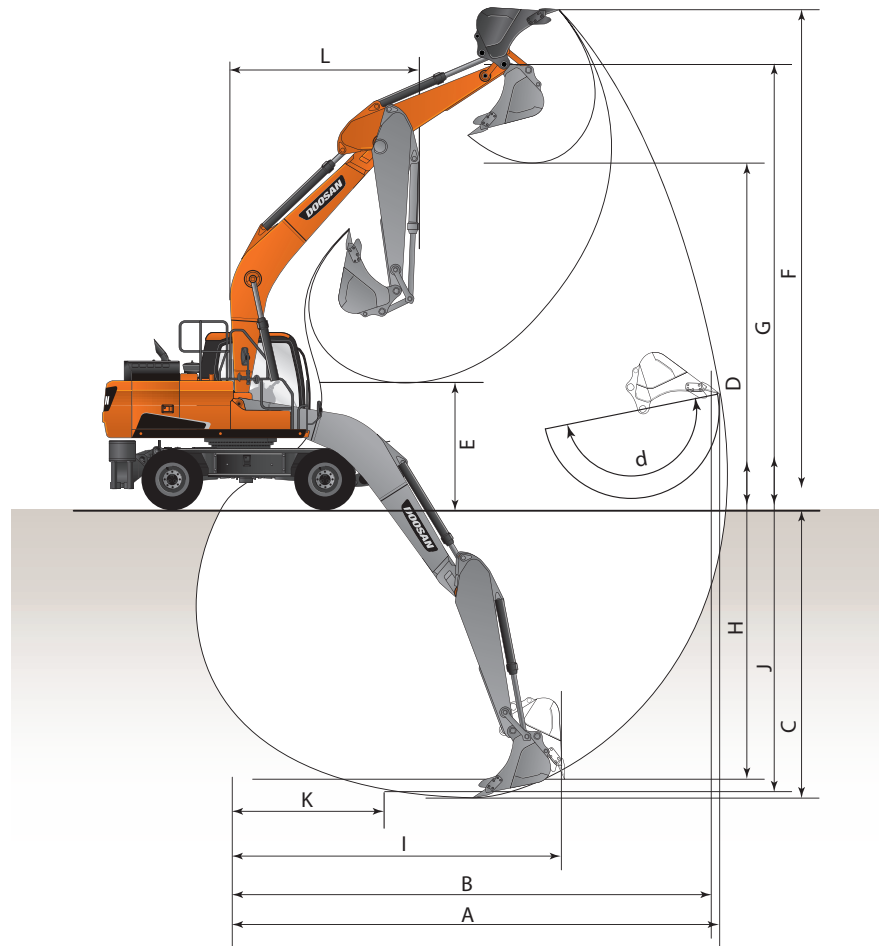

DX140W-5

			Mono Boom Dozer / Outriggers (2 R) (US20)	Mono Boom Outriggers (2 F / 2 R) (US30)	Articulated Boom Dozer / Outriggers (2 R) (US40)	Articulated Boom Outriggers (2 F / 2 R) (US50)
BOOM, MAIN	ft.-in. (mm)		14' 5" (4400)		11' (3350)	
BOOM, ARTICULATED			-		7' 3" (2200)	
ARM	ft.-in. (mm)		6' 11" (2100)			
BUCKET (SAE)	yd³ (m³)		0.73 (0.56)			
MAX. DIGGING REACH	A	ft.-in. (mm)	24' 11" (7585)		26' 11" (8210)	
MAX. DIGGING REACH (GROUND)	B	ft.-in. (mm)	24' 2" (7375)		26' 4" (8020)	
MAX. DIGGING DEPTH	C	ft.-in. (mm)	14' 9" (4490)		16' 6" (5025)	
MAX. LOADING HEIGHT	D	ft.-in. (mm)	19' 4" (5905)		22' (6715)	
MIN. LOADING HEIGHT	E	ft.-in. (mm)	8' 7" (2625)		11' (3365)	
MAX. DIGGING HEIGHT	F	ft.-in. (mm)	26' 11" (8195)		29' 9" (9060)	
MAX. BUCKET PIN HEIGHT	G	ft.-in. (mm)	23' 5" (7125)		26' (7930)	
MAX. VERTICAL WALL DEPTH	H	ft.-in. (mm)	11' 4" (3445)		12' 7" (3840)	
MAX. RADIUS VERTICAL	I	ft.-in. (mm)	18' (5480)		19' 1" (5825)	
MAX. DEPTH TO 8' LINE	J	ft.-in. (mm)	13' 10" (4215)		16' 1" (4905)	
MIN. RADIUS 8' LINE	K	ft.-in. (mm)	6' 11" (2105)		2' 10" (865)	
MIN. SWING RADIUS	L	ft.-in. (mm)	7' 8" (2340)		8' 8" (2650)	
BUCKET ANGLE (DEG)	d	Degrees	174°			
DIGGING FORCE, BUCKET (PCSA)		lb.f. (kgf)	20,349 (9230)		22,487 (10,200)	
DIGGING FORCE, ARM		lb.f. (kgf)	17,064 (7740)			
COUNTERWEIGHT		lb. (kg)	4740 (2150)			
OPERATING WEIGHT		lb. (kg)	34,203 (15,510)	34,875 (15,820)	36,180 (16,410)	36,852 (16,720)

Specifications

Working Range

DX190W-5

			Mono Boom Dozer / Outriggers (2 R) (US20)	Mono Boom Outriggers (2 F / 2 R) (US30)	Articulated Boom Dozer / Outriggers (2 R) (US40)	Articulated Boom Outriggers (2 F / 2 R) (US50)
BOOM, MAIN		ft.-in. (mm)	17' 1" (5200)		12' 6" (3820)	
BOOM, ARTICULATED			-		6' 4" (1940)	
ARM		ft.-in. (mm)	8' 6" (2600)		8' 6" (2600)	7' 7" (2300)
BUCKET (SAE)		yd ³ (m ³)	1.05 (0.80)			
MAX. DIGGING REACH	A	ft.-in. (mm)	30' 4" (9255)		31' 8" (9645)	30' 8" (9340)
MAX. DIGGING REACH (GROUND)	B	ft.-in. (mm)	29' 8" (9050)		31' (9450)	30' (9150)
MAX. DIGGING DEPTH	C	ft.-in. (mm)	18' 9" (5725)		19' 5" (5915)	18' 5" (5610)
MAX. LOADING HEIGHT	D	ft.-in. (mm)	22' 2" (6765)		25' 3" (7705)	24' 6" (7460)
MIN. LOADING HEIGHT	E	ft.-in. (mm)	8' 6" (2595)		10' 2" (3105)	11' 1" (3375)
MAX. DIGGING HEIGHT	F	ft.-in. (mm)	31' (9440)		34' 6" (10,510)	33' 8" (10,270)
MAX. BUCKET PIN HEIGHT	G	ft.-in. (mm)	26' 10" (8180)		29' 11" (9120)	29' 1" (8875)
MAX. VERTICAL WALL DEPTH	H	ft.-in. (mm)	15' 7" (4740)		16' 1" (4900)	15' 2" (4630)
MAX. RADIUS VERTICAL	I	ft.-in. (mm)	20' 9" (6330)		19' 1" (5810)	18' 8" (5680)
MAX. DEPTH TO 8' LINE	J	ft.-in. (mm)	18' 2" (5530)		19' 1" (5815)	18' 1" (5505)
MIN. RADIUS 8' LINE	K	ft.-in. (mm)	9' (2755)		3' 1" (935)	3' 1" (930)
MIN. SWING RADIUS	L	ft.-in. (mm)	10' 5" (3170)		10' 9" (3265)	
BUCKET ANGLE (DEG)	d	Degrees	182°			
DIGGING FORCE, BUCKET (PCSA)		lbf. (kgf)	28,219 (12,800)			
DIGGING FORCE, ARM		lbf. (kgf)	20,944 (9500)		20,944 (9500)	22,487 (10,200)
COUNTERWEIGHT		lb. (kg)	7672 (3480)			
OPERATING WEIGHT		lb. (kg)	43,431 (19,700)	44,644 (20,250)	43,541 (19,750)	44,754 (20,300)

DX210W-5

			Mono Boom Dozer / Outriggers (2 R) (US20)	Mono Boom Outriggers (2 F / 2 R) (US30)	Articulated Boom Dozer / Outriggers (2 R) (US40)	Articulated Boom Outriggers (2 F / 2 R) (US50)
BOOM, MAIN		ft.-in. (mm)	18' 4" (5600)		12' 7" (3840)	
BOOM, ARTICULATED			-		6' 4" (1920)	
ARM		ft.-in. (mm)	9' (2750)		7' 10" (2400)	
BUCKET (SAE)		yd ³ (m ³)	1.12 (0.86)			
MAX. DIGGING REACH	A	ft.-in. (mm)	31' 10" (9705)		30' 9" (9385)	
MAX. DIGGING REACH (GROUND)	B	ft.-in. (mm)	31' 2" (9505)		30' 1" (9175)	
MAX. DIGGING DEPTH	C	ft.-in. (mm)	19' 4" (5905)		18' 5" (5605)	
MAX. LOADING HEIGHT	D	ft.-in. (mm)	23' 4" (7115)		24' 8" (7530)	
MIN. LOADING HEIGHT	E	ft.-in. (mm)	9' 4" (2840)		10' 10" (3310)	
MAX. DIGGING HEIGHT	F	ft.-in. (mm)	32' 5" (9870)		34' 3" (10,435)	
MAX. BUCKET PIN HEIGHT	G	ft.-in. (mm)	28' 1" (8570)		29' 6" (8985)	
MAX. VERTICAL WALL DEPTH	H	ft.-in. (mm)	17' 4" (5280)		15' 10" (4830)	
MAX. RADIUS VERTICAL	I	ft.-in. (mm)	20' 11" (6365)		16' 7" (5060)	
MAX. DEPTH TO 8' LINE	J	ft.-in. (mm)	18' 9" (5715)		17' 11" (5460)	
MIN. RADIUS 8' LINE	K	ft.-in. (mm)	10' 5" (3180)		3' 6" (1062)	
MIN. SWING RADIUS	L	ft.-in. (mm)	10' 10" (3300)		10' 9" (3285)	
BUCKET ANGLE (DEG)	d	Degrees	178°		177°	
DIGGING FORCE, BUCKET (PCSA)		lbf. (kgf)	31,306 (14,200)			
DIGGING FORCE, ARM		lbf. (kgf)	24,030 (10,900)		26,896 (12,200)	
COUNTERWEIGHT		lb. (kg)	8818 (4000)			
OPERATING WEIGHT		lb. (kg)	47,179 (21,400)	47,730 (21,650)	49,163 (22,300)	49,714 (22,550)

Lifting Capacity

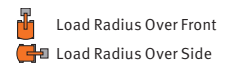

DX140W-5 (US20)

Boom, Std: 14' 5" (4400 mm) Arm: 6' 11" (2100 mm) Counter Weight: 4740 lb. (2150 kg) Tire Size: 10.00R20 Bucket: None Unit: lb. (kg)

B (ft.)	A (ft.)	5' (1.5 m)		10' (3.0 m)		15' (4.5 m)		20' (6.0 m)		25' (7.5 m)		MAX REACH		
														A
20' (6 m)						* 7960 (* 3610)	* 7960 (* 3610)					* 6920 (* 3140)	* 6920 (* 3140)	15' 2" 4.63
15' (4.5 m)						* 12,460 (* 5650)	* 12,460 (* 5650)					* 6550 (* 2970)	* 6550 (* 2970)	18' 7" 5.68
10' (3 m)				* 21,120 (* 9580)	* 21,120 (* 9580)	* 14,670 (* 6650)	12,970 (5880)	* 9150 (* 4150)	8330 (3780)			* 6760 (* 3070)	* 6760 (* 3070)	20' 4" 6.19
5' (1.5 m)				* 20,090 (* 10,020)	* 20,090 (* 10,020)	* 16,570 (* 7520)	12,490 (5670)	* 12,360 (* 5610)	8160 (3700)			* 7470 (* 3390)	* 7470 (* 3390)	20' 9" 6.31
0 Ground Line				* 23,760 (* 10,780)	* 23,760 (* 10,780)	* 17,060 (* 7740)	12,210 (5540)	* 10,550 (* 4790)	8050 (3650)			* 8980 (* 4070)	7930 (3600)	19' 11" 6.07
-5' (-1.5 m)		(* 8490)	(* 8490)	* 22,080 (* 10,010)	* 22,080 (* 10,010)	* 15,310 (* 6940)	12,170 (5520)					* 11,980 (* 5430)	9370 (4250)	17' 8" 5.39
-10' (-3 m)				* 14,830 (* 6730)	* 14,830 (* 6730)							* 10,660 (* 4840)	* 10,660 (* 4840)	13' 5" 4.09

DX140W-5 (US30)

Boom, Std: 14' 5" (4400 mm) Arm: 6' 11" (2100 mm) Counter Weight: 4740 lb. (2150 kg) Tire Size: 10.00R20 Bucket: None Unit: lb. (kg)

B (ft.)	A (ft.)	5' (1.5 m)		10' (3.0 m)		15' (4.5 m)		20' (6.0 m)		25' (7.5 m)		MAX REACH		
														A
20' (6 m)						* 7960 (* 3610)	* 7960 (* 3610)					* 6920 (* 3140)	* 6920 (* 3140)	15' 2" 4.63
15' (4.5 m)						* 12,460 (* 5650)	* 12,460 (* 5650)					* 6550 (* 2970)	* 6550 (* 2970)	18' 7" 5.68
10' (3 m)				* 21,120 (* 9580)	* 21,120 (* 9580)	* 14,670 (* 6650)	* 14,670 (* 6650)	* 9150 (* 4150)	* 9150 (* 4150)			* 6760 (* 3070)	* 6760 (* 3070)	20' 4" 6.19
5' (1.5 m)				* 22,090 (* 10,020)	* 22,090 (* 10,020)	* 16,570 (* 7520)	15,050 (6830)	* 12,360 (* 5610)	9670 (4390)			* 7470 (* 3390)	* 7470 (* 3390)	20' 9" 6.31
0 Ground Line				* 23,760 (* 10,780)	* 23,760 (* 10,780)	* 17,060 (* 7740)	14,750 (6690)	* 10,550 (* 4790)	9560 (4340)			* 8980 (* 4070)	* 8980 (* 4070)	19' 11" 6.07
-5' (-1.5 m)		(* 8490)	(* 8490)	* 22,080 (* 10,010)	* 22,080 (* 10,010)	* 15,310 (* 6940)	14,710 (6670)					* 11,980 (* 5430)	11,180 (5070)	17' 8" 5.39
-10' (-3 m)				* 14,830 (* 6730)	* 14,830 (* 6730)							* 10,660 (* 4840)	* 10,660 (* 4840)	13' 5" 4.09

DX140W-5 (US40)

Boom, Artic.: 11' (3350 mm) & 7' 3" (2200 mm) Arm: 6' 11" (2100 mm) Counter Weight: 4740 lb. (2150 kg) Tire Size: 10.00R20 Bucket: None Unit: lb. (kg)

B (ft.)	A (ft.)	10' (3.0 m)		15' (4.5 m)		20' (6.0 m)		MAX REACH		
										A
20' (6 m)								* 8490 (* 3850)	* 8490 (* 3850)	12' 9" 3.89
15' (4.5 m)				* 10,310 (* 4680)	* 10,310 (* 4680)			* 7180 (* 3260)	* 7180 (* 3260)	18' 1" 5.52
10' (3 m)		* 14,500 (* 6570)	* 14,500 (* 6570)	* 11,460 (* 5200)	* 11,460 (* 5200)	* 10,220 (* 4640)	8800 (3990)	* 6860 (* 3110)	* 6860 (* 3110)	21' 1" 6.42
5' (1.5 m)				* 13,730 (* 6230)	13,280 (6020)	* 10,980 (* 4980)	8590 (3900)	* 7000 (* 3180)	6980 (3170)	22' 7" 6.88
0 Ground Line				* 15,810 (* 7170)	12,700 (5760)	* 11,850 (* 5380)	8350 (3790)	* 7550 (* 3420)	6710 (3040)	22' 11" 6.99
-5' (-1.5 M)				* 16,550 (* 7510)	12,400 (5620)	* 12,190 (* 5530)	8190 (3720)	* 8670 (* 3930)	6950 (3150)	22' 2" 6.76
-10' (-3 m)		* 22,060 (* 10,010)	* 22,060 (* 10,010)	* 15,680 (* 7110)	12,370 (5610)	* 11,280 (* 5120)	8200 (3720)	* 10,740 (* 4870)	7900 (3580)	20' 3" 6.17

DX140W-5 (US50)

Boom, Artic.: 11' (3350 mm) & 7' 3" (2200 mm) Arm: 6' 11" (2100 mm) Counter Weight: 4740 lb. (2150 kg) Tire Size: 10.00R20 Bucket: None Unit: lb. (kg)

B (ft.)	A (ft.)	10' (3.0 m)		15' (4.5 m)		20' (6.0 m)		MAX REACH		
										A
20' (6 m)								* 8490 (* 3850)	* 8490 (* 3850)	12' 9" 3.89
15' (4.5 m)				* 10,310 (* 4680)	* 10,310 (* 4680)			* 7180 (* 3260)	* 7180 (* 3260)	18' 1" 5.52
10' (3 m)		* 14,500 (* 6570)	* 14,500 (* 6570)	* 11,460 (* 5200)	* 11,460 (* 5200)	* 10,220 (* 4640)	* 10,220 (* 4640)	* 6860 (* 3110)	* 6860 (* 3110)	21' 1" 6.42
5' (1.5 m)				* 13,730 (* 6230)	* 13,730 (* 6230)	* 10,980 (* 4980)	10,170 (4610)	* 7000 (* 3180)	* 7000 (* 3180)	22' 7" 6.88
0 Ground Line				* 15,810 (* 7170)	15,340 (6960)	* 11,850 (* 5380)	9920 (4500)	* 7550 (* 3420)	* 7550 (* 3420)	22' 11" 6.99
-5' (-1.5 M)				* 16,550 (* 7510)	15,020 (6810)	* 12,190 (* 5530)	9760 (4420)	* 8670 (* 3930)	8240 (3740)	22' 2" 6.76
-10' (-3 m)		* 22,060 (* 10,010)	* 22,060 (* 10,010)	* 15,680 (* 7110)	14,990 (6800)	* 11,280 (* 5120)	9760 (4430)	* 10,740 (* 4870)	9390 (4260)	20' 3" 6.17

- Load point is the end of the arm. Lift capacities shown do not exceed 75% of minimum tipping loads or 87% of hydraulic capacities.
- Capacities marked with an asterisk (*) are limited by hydraulic capacities. The least stable position is over the side
- The total mass of machine includes the mass of the boom, arm, counterweight, all operating fluids and 165 lb. (75 kg) operator
- Lift Capacities are in compliance with ISO 10567

Specifications

Lifting Capacity

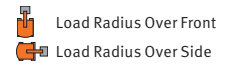

DX190W-5 (US20)

Boom, Std: 17' 1" (5200 mm) Arm: 8' 6" (2600 mm) Counter Weight: 7672 lb. (3480 kg) Tire Size: 10.00R20 Bucket: None Unit: lb. (kg)

B (ft.)	A (ft.)	5' (1.5 m)		10' (3.0 m)		15' (4.5 m)		20' (6.0 m)		25' (7.5 m)		MAX REACH		
														A
25' (7.5 m)												* 13,240 (* 5960)	* 13,240 (* 5960)	17' 3" 5.38
20' (6 m)								* 12,350 (* 5590)	11,500 (5360)			* 12,560 (* 5690)	10,070 (4500)	21' 7" 6.64
15' (4.5 m)						* 14,640 (* 6760)	* 14,640 (* 6760)	* 12,940 (* 5930)	11,320 (5260)			* 12,450 (* 5650)	8320 (3750)	24' 2" 7.38
10' (3 m)				* 28,450	* 28,450	* 18,220 (* 8450)	17,040 (7910)	* 14,400 (* 6630)	10,930 (5070)	* 12,640 (* 5780)	7740 (3600)	* 12,550 (* 5700)	7530 (3410)	25' 5" 7.76
5' (1.5 m)						* 21,510 (* 9960)	16,130 (7490)	* 15,920 (* 7340)	10,520 (4880)	* 13,090 (* 6020)	7590 (3520)	* 12,780 (* 5800)	7290 (3310)	25' 8" 7.83
0 Ground Line				* 16,100 (* 7030)	* 16,100 (* 7030)	* 22,930 (* 10,590)	15,630 (7260)	* 16,750 (* 7730)	10,240 (4750)			* 13,050 (* 5920)	7530 (3410)	24' 11" 7.6
-5' (-1.5 m)		* 16,660 (* 7450)	* 16,660 (* 7450)	* 27,110 (* 11,920)	* 27,110 (* 11,920)	* 22,200 (* 10,250)	15,520 (7220)	* 16,230 (* 7510)	10,160 (4710)			* 13,260 (* 6010)	8400 (3800)	23' 7.03
-10' (-3 m)				* 26,670 (* 12,340)	* 26,670 (* 12,340)	* 18,970 (* 8810)	15,730 (7310)		(4810)			* 13,080 (* 5940)	10,630 (4770)	19' 8" 6.04

DX190W-5 (US30)

Boom, Std: 17' 1" (5200 mm) Arm: 8' 6" (2600 mm) Counter Weight: 4740 lb. (2150 kg) Tire Size: 10.00R20 Bucket: None Unit: lb. (kg)

B (ft.)	A (ft.)	5' (1.5 m)		10' (3.0 m)		15' (4.5 m)		20' (6.0 m)		25' (7.5 m)		MAX REACH		
														A
25' (7.5 m)												* 13,240 (* 5960)	* 13,240 (* 5960)	17' 3" 5.38
20' (6 m)								* 12,350 (* 5590)	* 12,350 (* 5590)			* 12,560 (* 5690)	12,370 (5530)	21' 7" 6.64
15' (4.5 m)						* 14,640 (* 6760)	* 14,640 (* 6760)	* 12,940 (* 5930)	* 12,940 (* 5930)			* 12,450 (* 5650)	10,240 (4610)	24' 2" 7.38
10' (3 m)				* 28,450	* 28,450	* 18,220 (* 8450)	* 18,220 (* 8450)	* 14,400 (* 6630)	13,530 (6290)	* 12,640 (* 5780)	9550 (4440)	* 12,550 (* 5700)	9290 (4210)	25' 5" 7.76
5' (1.5 m)						* 21,510 (* 9960)	20,550 (9560)	* 15,920 (* 7340)	13,110 (6090)	* 13,090 (* 6020)	9390 (4360)	* 12,780 (* 5800)	9020 (4090)	25' 8" 7.83
0 Ground Line				* 16,100 (* 7030)	* 16,100 (* 7030)	* 22,930 (* 10,590)	20,010 (9320)	* 16,750 (* 7730)	12,810 (5950)			* 13,050 (* 5920)	9330 (4230)	24' 11" 7.6
-5' (-1.5 m)		* 16,660 (* 7450)	* 16,660 (* 7450)	* 27,110 (* 11,920)	* 27,110 (* 11,920)	* 22,200 (* 10,250)	19,890 (9260)	* 16,230 (* 7510)	12,730 (5910)			* 13,260 (* 6010)	10,440 (4730)	23' 7.03
-10' (-3 m)				* 26,670 (* 12,340)	* 26,670 (* 12,340)	* 18,970 (* 8810)	* 18,970 (* 8810)		(6010)			* 13,080 (* 5940)	* 13,080 (* 5940)	19' 8" 6.04

DX190W-5 (US40)

Boom, Artic.: 12' 6" (3820 mm) & 6' 4" (1940 mm) Arm: 8' 6" (2600 mm) Counter Weight: 4740 lb. (2150 kg) Tire Size: 10.00R20 Bucket: None Unit: lb. (kg)

B (ft.)	A (ft.)	10' (3.0 m)		15' (4.5 m)		20' (6.0 m)		25' (7.5 m)		MAX REACH			
												A	
25' (7.5 m)				* 11,430 (* 5120)	* 11,430 (* 5120)					* 12,400 (* 5590)	* 12,400 (* 5590)	17' 9" 5.52	
20' (6 m)				* 11,460 (* 5250)	* 11,460 (* 5250)	* 11,310 (* 5120)	* 11,310 (* 5120)			* 11,840 (* 5370)	9690 (4330)	22' 6.75	
15' (4.5 m)		* 18,660	* 18,660	* 13,810 (* 6400)	* 13,810 (* 6400)	* 11,990 (* 5500)	11,230 (5220)			* 11,820 (* 5360)	8060 (3630)	24' 6" 7.49	
10' (3 m)				* 17,530 (* 8150)	16,740 (7760)	* 13,560 (* 6250)	10,820 (5020)	* 12,020 (* 5480)	7700 (3580)		* 12,030 (* 5460)	7330 (3320)	25' 9" 7.86
5' (1.5 m)				* 20,890 (* 9680)	15,870 (7370)	* 15,230 (* 7030)	10,420 (4830)	* 12,660 (* 5810)	7550 (3500)	* 12,380 (* 5620)	7130 (3230)	26' 7.92	
0 Ground Line				* 22,490 (* 10,390)	15,500 (7200)	* 16,350 (* 7540)	10,180 (4720)	* 12,980 (* 6000)	7480 (3470)		* 12,810 (* 5810)	7390 (3350)	25' 3" 7.7
-5' (-1.5 m)				* 22,320 (* 10,300)	15,500 (7210)	* 16,380 (* 7570)	10,150 (4710)				* 13,240 (* 6000)	8280 (3740)	23' 5" 7.14

DX190W-5 (US50)

Boom, Artic.: 12' 6" (3820 mm) & 6' 4" (1920 mm) Arm: 7' 7" (2300 mm) Counter Weight: 4740 lb. (2150 kg) Tire Size: 10.00R20 Bucket: None Unit: lb. (kg)

B (ft.)	A (ft.)	10' (3.0 m)		15' (4.5 m)		20' (6.0 m)		25' (7.5 m)		MAX REACH			
												A	
25' (7.5 m)				* 11,430 (* 5120)	* 11,430 (* 5120)					* 12,400 (* 5590)	* 12,400 (* 5590)	17' 9" 5.52	
20' (6 m)				* 11,460 (* 5250)	* 11,460 (* 5250)	* 11,310 (* 5120)	* 11,310 (* 5120)			* 11,840 (* 5370)	* 11,840 (5340)	22' 6.75	
15' (4.5 m)		* 18,660	* 18,660	* 13,810 (* 6400)	* 13,810 (* 6400)	* 11,990 (* 5500)	* 11,990 (* 5500)			* 11,820 (* 5360)	9960 (4490)	24' 6" 7.49	
10' (3 m)				* 17,530 (* 8150)	* 17,530 (* 8150)	* 13,560 (* 6250)	13,450 (6250)	* 12,020 (* 5480)	9530 (4430)		* 12,030 (* 5460)	9080 (4110)	25' 9" 7.86
5' (1.5 m)				* 20,890 (* 9680)	20,320 (9450)	* 15,230 (* 7030)	13,030 (6050)	* 12,660 (* 5810)	9380 (4350)	* 12,380 (* 5620)	8850 (4010)	26' 7.92	
0 Ground Line				* 22,490 (* 10,390)	19,920 (9280)	* 16,350 (* 7540)	12,780 (5930)	* 12,980 (* 6000)	9300 (4310)		* 12,810 (* 5810)	9190 (4170)	25' 3" 7.7
-5' (-1.5 m)				* 22,320 (* 10,300)	19,920 (9280)	* 16,380 (* 7570)	12,750 (5920)				* 13,240 (* 6000)	10,300 (4660)	23' 5" 7.14

- Load point is the end of the arm. Lift capacities shown do not exceed 75% of minimum tipping loads or 87% of hydraulic capacities.
- Capacities marked with an asterisk (*) are limited by hydraulic capacities. The least stable position is over the side
- The total mass of machine includes the mass of the boom, arm, counterweight, all operating fluids and 165 lb. (75 kg) operator
- Lift Capacities are in compliance with ISO 10567

Lifting Capacity

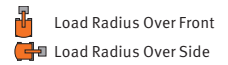

DX210W-5 (US20)

Boom, Std: 18' 4" (5600 mm) Arm: 9' (2750 mm) Counter Weight: 8818 lb. (4000 kg) Tire Size: 10.00R20 Bucket: None Unit: lb. (kg)

B (ft.)	A (ft.)	10' (3.0 m)		15' (4.5 m)		20' (6.0 m)		25' (7.5 m)		MAX REACH		
												A
25' (7.5 m)						(* 4730)	(* 4730)			* 10,110 (* 4540)	* 10,110 (* 4540)	19' 6" 6.05
20' (6 m)						* 12,460 (* 5680)	* 12,460 (* 5680)			* 9330 (* 4220)	* 9330 (* 4220)	23' 4" 7.17
15' (4.5 m)				* 15,820 (* 7320)	* 15,820 (* 7320)	* 13,440 (* 6180)	12,980 (6030)	* 11,540 (* 5620)	9080 (4230)	* 9180 (* 4160)	8700 (3920)	25' 8" 7.84
10' (3 m)				* 19,500 (* 9050)	19,320 (8960)	* 15,040 (* 6930)	12,460 (5780)	* 12,840 (* 5890)	8890 (4130)	* 9430 (* 4290)	7950 (3600)	26' 10" 8.18
5' (1.5 m)				* 22,560 (* 10,440)	18,220 (8460)	* 16,550 (* 7640)	11,950 (5540)	* 13,440 (* 6190)	8660 (4020)	* 10,110 (* 4590)	7720 (3500)	27' 8.24
0 Ground Line				* 23,640 (* 10,910)	17,670 (8210)	* 17,310 (* 7990)	11,610 (5390)	* 13,580 (* 6280)	8500 (3940)	* 11,370 (* 5160)	7930 (3600)	26' 3" 8.01
-5' (-1.5 m)		* 26,350 (* 11,610)	* 26,350 (* 11,610)	* 22,730 (* 10,480)	17,550 (8160)	* 16,840 (* 7790)	11,500 (5330)			* 12,890 (* 5850)	8740 (3950)	24' 6" 7.48
-10' (-3 m)		* 26,880 (* 12,410)	* 26,880 (* 12,410)	* 19,720 (* 9140)	17,770 (8260)	* 14,320 (* 6700)	11,660 (5400)			* 12,720 (* 5780)	10,690 (4800)	21' 4" 6.55

DX210W-5 (US30)

Boom, Std: 18' 4" (5600 mm) Arm: 9' (2750 mm) Counter Weight: 8818 lb. (4000 kg) Tire Size: 10.00R20 Bucket: None Unit: lb. (kg)

B (ft.)	A (ft.)	10' (3.0 m)		15' (4.5 m)		20' (6.0 m)		25' (7.5 m)		MAX REACH		
												A
25' (7.5 m)						(* 4730)	(* 4730)			* 10,110 (* 4540)	* 10,110 (* 4540)	19' 6" 6.05
20' (6 m)						* 12,460 (* 5680)	* 12,460 (* 5680)			* 9330 (* 4220)	* 9330 (* 4220)	23' 4" 7.17
15' (4.5 m)				* 15,820 (* 7320)	* 15,820 (* 7320)	* 13,440 (* 6180)	* 13,440 (* 6180)	* 11,540 (* 5620)	11,030 (5130)	* 9180 (* 4160)	* 9180 (* 4160)	25' 8" 7.84
10' (3 m)				* 19,500 (* 9050)	* 19,500 (* 9050)	* 15,040 (* 6930)	* 15,040 (* 6930)	* 12,840 (* 5890)	10,830 (5030)	* 9430 (* 4290)	* 9430 (* 4290)	26' 10" 8.18
5' (1.5 m)				* 22,560 (* 10,440)	* 22,560 (* 10,440)	* 16,550 (* 7640)	14,740 (6840)	* 13,440 (* 6190)	10,590 (4910)	* 10,110 (* 4590)	9430 (4280)	27' 8.24
0 Ground Line				* 23,640 (* 10,910)	22,460 (10,460)	* 17,310 (* 7990)	14,380 (6680)	* 13,580 (* 6280)	10,420 (4830)	* 11,370 (* 5160)	9710 (4410)	26' 3" 8.01
-5' (-1.5 m)		* 26,350 (* 11,610)	* 26,350 (* 11,610)	* 22,730 (* 10,480)	22,340 (10,410)	* 16,840 (* 7790)	14,260 (6620)			* 12,890 (* 5850)	10,730 (4850)	24' 6" 7.48
-10' (-3 m)		* 26,880 (* 12,410)	* 26,880 (* 12,410)	* 19,720 (* 9140)	* 19,720 (* 9140)	* 14,320 (* 6700)	* 14,320 (6690)			* 12,720 (* 5780)	* 12,720 (* 5780)	21' 4" 6.55

DX210W-5 (US40)

Boom, Artic.: 12' 7" (3840 mm) & 6' 4" (1920 mm) Arm: 7' 10" (2400 mm) Counter Weight: 8818 lb. (4000 kg) Tire Size: 10.00R20 Bucket: None Unit: lb. (kg)

B (ft.)	A (ft.)	10' (3.0 m)		15' (4.5 m)		20' (6.0 m)		25' (7.5 m)		MAX REACH		
												A
25' (7.5 m)				* 10,720 (* 4860)	* 10,720 (* 4860)					* 9710 (* 4400)	* 9710 (* 4400)	18' 5" 5.6
20' (6 m)				* 11,040 (* 5010)	* 11,040 (* 5010)	* 11,060 (* 5020)	* 11,060 (* 5020)			* 8340 (* 3780)	* 8340 (* 3780)	22' 4" 6.8
15' (4.5 m)				* 13,580 (* 6160)	* 13,580 (* 6160)	* 11,940 (* 5410)	* 11,940 (* 5410)	* 7790 (* 3540)	* 7790 (* 3540)	* 7790 (* 3530)	* 7790 (* 3530)	24' 7" 7.5
10' (3 m)				* 17,530 (* 7950)	* 17,530 (* 7950)	* 13,690 (* 6210)	* 13,690 (* 6210)	* 12,240 (* 5550)	10,300 (4670)	* 7660 (* 3470)	* 7660 (* 3470)	25' 9" 7.86
5' (1.5 m)				* 21,270 (* 9650)	* 21,270 (* 9650)	* 15,600 (* 7070)	14,000 (6350)	* 13,120 (* 5950)	10,100 (4580)	* 7860 (* 3570)	* 7860 (* 3570)	26' 7.92
0 Ground Line				* 23,430 (* 10,630)	21,200 (9620)	* 17,050 (* 7730)	13,700 (6210)	* 13,800 (* 6260)	10,000 (4540)	* 8440 (* 3830)	* 8440 (* 3830)	25' 2" 7.68
-5' (-1.5 m)		* 26,180 (* 11,870)	* 26,180 (* 11,870)	* 23,880 (* 10,830)	21,180 (9610)	* 17,560 (* 7960)	13,650 (6190)			* 9620 (* 4370)	* 9620 (* 4370)	23' 4" 7.12

DX210W-5 (US50)

Boom, Artic.: 12' 7" (3840 mm) & 6' 4" (1920 mm) Arm: 7' 10" (2400 mm) Counter Weight: 8818 lb. (4000 kg) Tire Size: 10.00R20 Bucket: None Unit: lb. (kg)

B (ft.)	A (ft.)	10' (3.0 m)		15' (4.5 m)		20' (6.0 m)		25' (7.5 m)		MAX REACH		
												A
25' (7.5 m)				* 10,720 (* 4860)	* 10,720 (* 4860)					* 9710 (* 4400)	* 9710 (* 4400)	18' 5" 5.6
20' (6 m)				* 11,040 (* 5010)	* 11,040 (* 5010)	* 11,060 (* 5020)	* 11,060 (* 5020)			* 8340 (* 3780)	* 8340 (* 3780)	22' 4" 6.8
15' (4.5 m)				* 13,580 (* 6160)	* 13,580 (* 6160)	* 11,940 (* 5410)	* 11,940 (* 5410)	* 7790 (* 3540)	* 7790 (* 3540)	* 7790 (* 3530)	* 7790 (* 3530)	24' 7" 7.5
10' (3 m)				* 17,530 (* 7950)	* 17,530 (* 7950)	* 13,690 (* 6210)	* 13,690 (* 6210)	* 12,240 (* 5550)	10,410 (4720)	* 7660 (* 3470)	* 7660 (* 3470)	25' 9" 7.86
5' (1.5 m)				* 21,270 (* 9650)	* 21,270 (* 9650)	* 15,600 (* 7070)	14,150 (6420)	* 13,120 (* 5950)	10,220 (4630)	* 7860 (* 3570)	* 7860 (* 3570)	25' 12" 7.92
0 Ground Line				* 23,430 (* 10,630)	21,430 (9720)	* 17,050 (* 7730)	13,850 (6280)	* 13,800 (* 6260)	10,120 (4590)	* 8,440 (* 3830)	* 8440 (* 3830)	25' 2" 7.68
-5' (-1.5 m)		* 26,180 (* 11,870)	* 26,180 (* 11,870)	* 23,880 (* 10,830)	21,410 (9710)	* 17,560 (* 7960)	13,800 (6260)			* 9620 (* 4370)	* 9620 (* 4370)	23' 4" 7.12

- Load point is the end of the arm. Lift capacities shown do not exceed 75% of minimum tipping loads or 87% of hydraulic capacities.
- Capacities marked with an asterisk (*) are limited by hydraulic capacities. The least stable position is over the side
- The total mass of machine includes the mass of the boom, arm, counterweight, all operating fluids and 165 lb. (75 kg) operator
- Lift Capacities are in compliance with ISO 10567

Specifications

Standard/Optional Equipment

- Standard Equipment
- Optional Equipment
- N/A

	DX140W-5	DX190W-5	DX210W-5
ENGINE			
Emissions (EPA)	T4	T4	T4
High Pressure Common Rail (HPCR)	•	•	•
Turbocharger, WasteGate	•	•	•
Cooled Exhaust Gas Recirculation (CEGR)	•	•	•
Selective Catalyst Reduction (SCR)	•	•	•
Diesel Exhaust Fluid (DEF)	•	•	•
Fuel Filter with Water Separator	•	•	•
Fuel Filter with Water Separator & Heater	■	■	■
Coolant Recovery Tank	•	•	•
Variable Speed Cooling Fan (Engine Driven with Electric Clutch)	•	•	•
Dual Element Dry-type Air Filter with Evacuator	•	•	•
Pre Cleaner	•	•	•
Electronic Engine Control (ECU)	•	•	•
Auto-Idle	•	•	•
Overheat & Low Oil Pressure Engine Protection	•	•	•
Block Heater	■	■	■
Diesel Powered Coolant Heater	■	■	■
Fuel Filler Pump	■	■	■
HYDRAULIC			
Electronic Power Optimizing System (EPOS)	•	•	•
Bent Axis Piston Main Pump (Tandem)	•	•	•
Cross-Sensing Pump Control	•	•	•
Pilot-Operated Control Valves	•	•	•
Gear Pilot Pump	•	•	•
Smart Power Control (SPC)	•	•	•
Variable Speed Cooling Fan (Engine Driven with Electric Clutch)	•	•	•
Axial Piston Swing Motor	•	•	•
Spring Applied Hydraulic Release, Travel Brake	•	•	•
Spring Applied Hydraulic Release, Wing Brake	•	•	•
Axial Piston Travel Motor (High/Low, Auto)	•	•	•
Auxiliary Hydraulics, One-Way	•	•	•
Auxiliary Hydraulics, Two-Way	•	•	•
Auxiliary Hydraulics, Rotate	•	•	•
Adjustable Auxiliary Flow & Pressure, 10 Presets	•	•	•
Intelligent Floating Boom	■	■	■
Boom Lock Valve	■	■	■
DISPLAY MONITOR & WARNINGS			
Buzzer - Engine Oil Pressure - Coolant Temperature	•	•	•
Gauges - Fuel Level - DEF Level - Engine Coolant Temperature - Hydraulic Oil Temperature - Engine RPM - Battery Voltage - Hydraulic Pump Pressure - ECO - Digital Clock - Trip Meter - Hour Meter - Fuel Consumption	•	•	•
Warning & Indicator Lights - Seat Belt - Error Code - SCR Warning - Check Engine - Engine Oil Pressure - Engine Pre-Heat Engaged - Radiator Coolant Temperature - Air Filter - Fuel Level - DEF Level - Low - Water in Fuel - Battery Charge - Work Lights On - Hydraulic Oil Temperature - Hydraulic Charge Pressure - Hydraulic Pilot Filter - Hydraulic Return Filter - Brake Oil Pressure	•	•	•
Swing Alarm	■	■	■
Travel Alarm	•	•	•

	DX140W-5	DX190W-5	DX210W-5
CABIN			
Steel, All-Weather & Sound Suppressed	•	•	•
ROPS (ISO 12117-2:2008)	•	•	•
Viscous Mount	•	•	•
Front Window with Wiper/Washer	•	•	•
Wiper, Lower Front Window	■	■	■
Tinted Safety Glass	•	•	•
Skylight	•	•	•
Visor, Front Window and Skylight	•	•	•
Pull Up Type Top Front Window	•	•	•
Removable Lower Front Window with Storage Behind Seat	•	•	•
Adjustable Sliding Side Door Window	•	•	•
Defrost, Front Window	•	•	•
Lockable Doors	•	•	•
Seat - Heated - 2" (51 mm) Seat Belt - Air Suspension - Adjustable Height & Recline - Adjustable Fore/Aft - Adjustable Arm Rests	•	•	•
3" (76 mm) Seat Belt	■	■	■
Control Stands - Height Adjustable - Mounted to Seat Base	•	•	•
Foot Rest	•	•	•
Storage for Operator's Manuals	•	•	•
Mirrors	•	•	•
Fully Automatic HVAC w/ ambient temperature sensor	•	•	•
7" Multi-Function LCD	•	•	•
Cigarette Lighter	•	•	•
AM/FM Stereo with MP3 port	•	•	•
Speakers (2)	•	•	•
Antenna, Roof Mounted	•	•	•
Emergency Breakout Tool	•	•	•
Hot/Cold Beverage Compartment	•	•	•
Power Socket, 12V	•	•	•
Beverage Holder	•	•	•
Interior Light	•	•	•
Coat Hanger	•	•	•
Rain Shield	■	■	■
Guard, FOGS	■	■	■
Guard, Front Window Guard	■	■	■
Vandalism Window Covers	■	■	■

Standard/Optional Equipment

- Standard Equipment
- Optional Equipment
- N/A

	DX140W-5	DX190W-5	DX210W-5
ELECTRICAL			
System Voltage - 24 V	•	•	•
Alternator - 24V, 80 Amp	•	•	•
2 x 12V Batteries, 150 AH Reserve Capacity	•	•	•
Blade Type Fuse Panel	•	•	•
Main Circuit Breaker	•	•	•
Light, Hazard	•	•	•
Light, Turn (L & R)	•	•	•
Light, Work (Halogen): Machine (2), Boom (2)	•	•	•
Light, Work (Halogen): Cabin (2)	■	■	■
Light, Work (Halogen): Cabin (4 Front, 2 Rear)	■	■	■
Rotating Beacon	■	■	■
Hour Meter	•	•	•
Engine Restart Prevention System	•	•	•
Rear View Camera	•	•	•
Side View Cameras	■	■	■
Laptop Service Port	•	•	•
Self-Diagnostics System	•	•	•
DoosanCONNECT™ Telematics	•	•	•
CONTROLS			
Steering Wheel	•	•	•
FnR Lever	•	•	•
Accelerator Pedal	•	•	•
Brake Pedal	•	•	•
Swing Lock Pin	•	•	•
Joystick Controls	•	•	•
Pattern Control Change Valve (SAE, ISO)	-	•	•
Joystick Machine Control Switches/Buttons - FnR - Horn - Deceleration	•	•	•
Joystick Attachment Control Switches/Buttons - One-way - Two-way - Power Boost	•	•	•
Foot Pedal Attachment Control	•	•	•
Control Stands - Height Adjustable - Sliding (Fore/Aft)	•	•	•
Engine Speed Control Dial	•	•	•
Switches & Indicators, Steering Column - Steering Column Positional Lever - Work/Travel Selector Switch - Turn Signal Control Lever - Hazard Warning Switch - Turn Signal/Hazard Light Indicators - Wiper & Washer Control - Horn Button - High/Low Beam Control	•	•	•
Switches, Console Mounted - Starter (key) - Park Brake - Travel Speed Selector - Axle Oscillation Lock - Road Lights - Work Lights - Travel Alarm - Outrigger Selection - Cruise Control - Boom Float - DeSOX - Auxiliary Mode	•	•	•
Emergency Stop Switch	•	•	•
Power Mode (P+, P, S, E)	•	•	•
Work Mode (Digging, Lifting, Breaker, Shear)	•	•	•
Smart Power Control (SPC)	•	•	•
Jog Dial Display Control	•	•	•
Wiper Control Panel	•	•	•
Audio Control Panel	•	•	•
Horn	•	•	•

	DX140W-5	DX190W-5	DX210W-5
UNDERCARRIAGE			
Tire Size - 10.00R20 16 Ply Rating	•	•	•
Transmission, 2 Speed Power-Shift With Creep	•	•	•
Planetary Drive, (Front & Rear Axle)	•	•	•
Oscillating (±8°) Front Axle, Lockable	•	•	•
Steering front axle	•	•	•
Dozer	•	•	•
Outriggers Front (In Place of Dozer)	■	■	■
Outriggers Rear	•	•	•
Toolbox	•	•	•
OTHER			
Centralized Lubrication - Boom - Arm - Swing	•	•	•
Emergency Steering	•	•	•
Handrails & Service Platforms	•	•	•
Skid-Resistant Steps & Service Platforms	•	•	•
Wheel Chocks	•	•	•
Manuals - Operations & Maintenance - Parts - AEM Safety Manual	•	•	•
DoosanCONNECT, 3 Year Subscription (Telematics)	•	•	•
Vandalism Protection - Lockable Panels - Lockable Fluid Fill Points - Anti-Theft Protection (Password)	•	•	•
Toolbox	•	•	•
Air Compressor	■	■	■

Standard Equipment based on Standard Boom (US20) configuration

DOOSAN STRONG



Printed on 10% recycled paper

1.877.745.7814
DoosanEquipment.com/WHEX

Doosan® and the Doosan logo are registered trademarks of Doosan Corp. in the United States and various other countries around the world. ©2017 Doosan Construction Equipment. All rights reserved.

DOOSAN